

fieldbus

Fieldbus Electronics and I/O



NUMATICS

Fieldbus Electronics and I/O 3-76

G2-1 Electronics 3-12

Features and Benefits	3
Communication Protocols	4-8
How to Order	9
AKC Communication Module	10
LH Mounting Cover Kit	10
Fieldbus Communication Module	11
Manual Configuration Module	11
I/O Module Assemblies	12
Flexiblok® Manifold Dimensional Drawing	13

G2-2 Electronics 14-42

Features and Benefits	14
Communication Protocols	15-26
Discrete I/O Modules	27
How to Order	28-32
Fieldbus Communication Module	33
Manual Configuration Module	34
I/O Block Assemblies	35-36
25 Pin Sub-D Connector Input	37
Dual 15 Pin Sub-D Connector Input	37
19 Pin M23 Circular Connector Digital I/O Module	38
25 Pin Sub-D Connector Output Module	39
Dual 25 Pin Sub-D Connector Output Module	39
Valve Side Sub-D Output Modules	40-41
Mounting Cover Assemblies	42
Dimensional Drawing	43

Individual Base Node 44-50

Features and Benefits	44
Communication Protocols	45-46
How to Order	47
Valve on Individual Base Node	48
Base Assemblies	49
Replacement Kits	50

Direct to PLC 51-57

Features and Benefits	51
I/O Modules Technical Data	52
How to Order	53-56
I/O Block Assemblies	57
25 Pin Sub-D I/O Module Assembly	58
Connector Kits	59

Cables and Accessories 60-76



G2-1 Fieldbus Communications Electronics

Why use Numatics Fieldbus communication electronics? *Modular Reality...*

- No internal wiring
- Up to 40 valve solenoids
- Discrete I/O status with short circuit protection
- Software or manual configuration
- Plug-together flexibility
- Conformance tested
- Shorted and open load diagnostics
- Universal input technology allows NPN or PNP sensor types with same input module.
- NEMA4/IP65
- Up to 16 discrete output points and 16 input points per communication node
- Low cost distribution options
- Used with 2002 and 2004 Series

Supported Protocols:

- DeviceNet
- Allen Bradley 1771 Remote I/O
- Profibus DP 1.5 MBps & 12MBps
- DeviceLogix
- CANopen - Consult Factory
- AS-i - Consult Factory





DeviceLogix

DeviceLogix is a Rockwell Automation technology that allows a DeviceNet node to be programmed to execute a sequence independently from the control for the main PLC/IPC. A DeviceLogix enabled DeviceNet node can be used in conjunction with a standard DeviceNet network, providing simple distributed control functionality. Additionally, it can also be used in a standalone application, without a network connection or PLC/IPC, to sequence pneumatic valves and control I/O. Numatics has integrated this licensed technology into its DeviceNet compatible valve manifold series, which combine the functionality of a modular pneumatic valve system with integrated I/O.

Programming of the DeviceLogix enabled node is done using the industry standard DeviceNet commissioning software tool RSNetworkx for DeviceNet for Rockwell Automation. The programming software features an easily understandable graphics environment where the users can simply “drag and drop” logic function blocks (i.e. AND, NAND, OR, NOR, XOR, XNOR, RS LATCHES, COUNTERS and TIMERS) onto a page and interconnect them to develop the required sequence, or ladder logic programming can be used to develop a sequence. The programmed sequence is downloaded to the node via the standard DeviceNet communication connection, thus multiple nodes can be programmed simultaneously on the same network.



Technical Data

ELECTRICAL DATA	VOLTAGE	CURRENT
BUS Power	11-25 VDC	0.025 amps.
Valve & Discrete I/O	24 VDC +/- 10%	4 amps. maximum
Aux Power Connector	Single key 4 pin 12mm (Micro) connector	
Communication Connector	Single key 5 pin 12 mm (Micro) connector	
LED's	Module status, Network status, Ext fault & Aux power and logic enabled	

OPERATING DATA		
Temperature Range	+32° to +115° F (0° to +46° C)	
Humidity	95% relative humidity, non-condensing	
Moisture	Designed to meet NEMA 4 / IP65 requirements	

CONFIGURATION DATA	
Communication Module	Contains all communication electronics as well as short circuit protected driver circuitry for up to 24 valve solenoids. Supports auto-baud detection and auto-device replacement (ADR) feature.
Manual Configuration Module (MCM)	Optional module for use when a manual configuration method is preferred.
Maximum Valve Solenoid Outputs	24 (2002 Series)
Maximum Discrete I/O Points	16

Numatics' DeviceNet modules features Polled, Change of State (COS), Cyclic and combinations message capability.

Electronic Data Sheet (EDS) file and technical manuals are available in the download section of the Numatics, Inc. web site at: www.numatics.com/fieldbus



G2-1 Electronics

DeviceNet

DeviceNet is an open protocol bus communication system developed by Allen-Bradley based on Controller Area Network (CAN) technology. The governing body for DeviceNet is the Open DeviceNet Vendor Association (ODVA). The ODVA controls the DeviceNet specification and oversees product conformance testing.

Numatics G2-1 DeviceNet modules have been tested and approved for conformance by the ODVA.

More information about DeviceNet and the ODVA can be obtained from the following WEB site:

Open DeviceNet Vendors Association (ODVA)
www.odva.org



Technical Data

ELECTRICAL DATA		VOLTAGE	CURRENT
BUS Power		11-25 VDC	0.025 amps.
Valve & Discrete I/O		24 VDC +/- 10%	4 amps. maximum
Aux Power Connector	Single key 4 pin 12mm (Micro) connector		
Communication Connector	Single key 5 pin 12 mm (Micro) connector		
LED's	Module status, Network status, Ext fault & Aux power		
OPERATING DATA			
Temperature Range	+32° to +115° F (0° to +46° C)		
Humidity	95% relative humidity, non-condensing		
Moisture	Designed to meet NEMA 4 / IP65 requirements		
CONFIGURATION DATA			
Communication Module	Contains all communication electronics as well as short circuit protected driver circuitry for up to 24 valve solenoids. Supports auto-baud detection and auto-device replacement (ADR) feature.		
Manual Configuration Module (MCM)	Optional module for use when a manual configuration method is preferred.		
Maximum Valve Solenoid Outputs	24 (2002 Series), 16 (2004 Series)		
Maximum Discrete I/O Points	16		
Numatics' DeviceNet modules features Polled, Change of State (COS), Cyclic and combinations message capability.			
Electronic Data Sheet (EDS) file and technical manuals are available in the download section of the Numatics, Inc. web site at: www.numatics.com/fieldbus			



G2-1 Electronics

Allen Bradley 1771 Remote I/O

Allen-Bradley 1771 Remote I/O is a proprietary protocol based on a patented chipset. This chipset is obtained from Allen-Bradley and incorporated into the Numatics RIO module.

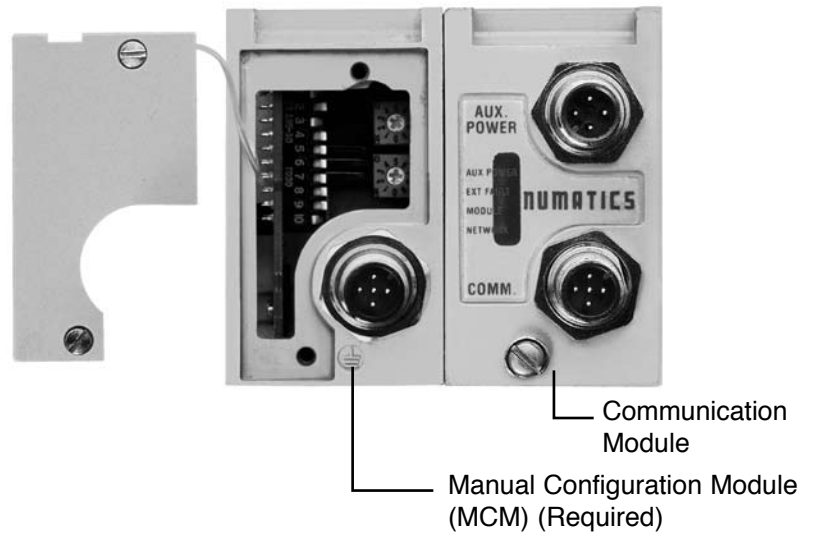

Technical Data

ELECTRICAL DATA	VOLTAGE	CURRENT
Valve & Discrete I/O	24 VDC +/- 10%	4 amps. maximum
Aux Power Connector	Single key 4 & 5 pin 12mm (Micro) connector	
Communication Connector	Single key 5 pin 12 mm (Micro) connector, Bus IN and OUT	
LED's	Communications status, ext. fault and auxiliary power	
OPERATING DATA		
Temperature Range	+32° to +115° F (0° to +46° C)	
Humidity	95% relative humidity, non-condensing	
Moisture	Designed to meet NEMA 4 / IP65 requirements	
CONFIGURATION DATA		
Communication Module	Contains all communication electronics as well as short circuit protected driver circuitry for up to 24 valve solenoids.	
Manual Configuration Module (MCM)	Module contains DIP and rotary switches for setting device configuration data	
Maximum Valve Solenoid Outputs	24 (2002 Series), 16 (2004 Series)	
Maximum Discrete I/O Points	16	
Rack Size	Rack size is set automatically to 1/4 rack	

This product incorporates technology which is licensed by Allen- Bradley Company, Inc. Allen-Bradley has not technically approved, nor does it warrant or support this product. All warranty and support for this product and its application is provided solely by Numatics, Incorporated.



Profibus DP (1.5 MBps & 12 MBps)

Profibus-DP is a vendor-independent, open fieldbus designed for communication between automation control systems and distributed I/O at the device level.

The 2002 Series - Profibus product is designed to conform to the Profibus standard EN50170. Certification is by the Profibus Interface Center (PIC) according to the guidelines determined by the Profibus Trade Organization (PTO). The certification process ensures interoperability for all Profibus devices.

More information about Profibus can be obtained at the following web sites:

Profibus Interface Center
www.aut.sea.siemens.com/pic/index.htm

Profibus Trade Organization
www.profibus.com

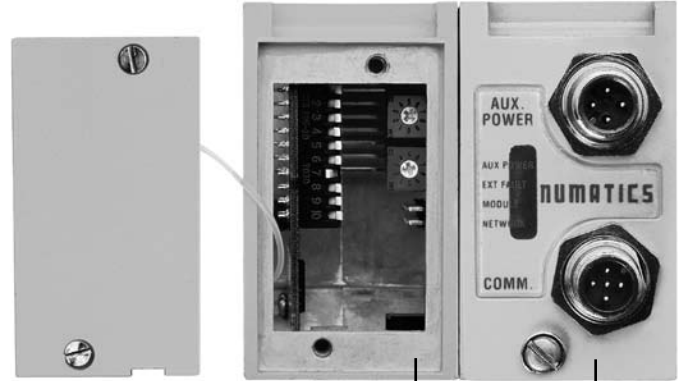

Manual Configuration Module (MCM)
 (Not required with Class II Master)

Communication Module

Technical Data

ELECTRICAL DATA		VOLTAGE	CURRENT
Valve & Discrete I/O		24 VDC +/- 10%	4 amps. maximum
Aux. Power Connectors	1.5 MBps 12 MBps	Single key 4 pin 12 mm (Micro) connector Single key 4 pin 12 mm (Micro) connector	
Communication Connector	1.5 MBps 12 MBps	5 pin 12 mm (Micro) connector 5 pin reverse key female (Micro) connector	
LED's	Module status, Network status, Ext fault and Auxiliary power		

OPERATING DATA	
Temperature Range	+32° to +115° F (0° to +46° C)
Humidity	95% relative humidity, non-condensing
Moisture	Designed to meet NEMA 4 / IP65 requirements

CONFIGURATION DATA	
Communication Module	Contains all communication electronics as well as short circuit protected driver circuitry for up to 24 valve solenoids.
Manual Configuration Module (MCM)	Module containing DIP and rotary switches for setting device configuration data.
Maximum Valve Solenoid Outputs	24
Maximum Discrete I/O Points	16, available with 12mm (micro) connectors or 25 pin sub-D styles

(GSD) File and technical manuals are available in the download section of the Numatics, Inc. website at: www.numatics.com/fieldbus.



G2-1 Electronics

Discrete I/O Modules

Discrete I/O modules are used to connect additional I/O devices to the valve manifold node. This provides for more efficient use of system resources when configuring an industrial network system.

Universal input modules feature technology that allows the same module to automatically recognize PNP or NPN type sensors without the need to add external pull-up resistors or manually select sensor type.

Input and output modules have two 12mm (micro) connectors. Each can be used individually (i.e. 1 I/O point per connector) or can be used for double point (i.e. connector 1 has two points of I/O). This standard feature further simplifies external I/O wiring.

Sub-D output module can be used to drive 16 additional coils on a separate manifold or 16 discrete output points.

Sub-D I/O module can be used for inputs and or up to a total of 16 I/O points.



Discrete I/O



Sub-D I/O

Technical Data

ELECTRICAL DATA

Inputs:

Supply Voltage	24 VDC ± 10%
Type	Sourcing (PNP), Sinking (NPN) or contact closure (universal input technology)
LED Indicator	Input status

Outputs:

Voltage	24 VDC +/- 10%
Current	0.5 amperes per output (4A max. per manifold)
Type	Sinking (NPN)
LED Indicator	Output status

OPERATING DATA

Temperature Range	+32° to +115° F (0° to +46° C)
Humidity	95% relative humidity, non-condensing
Moisture	Designed to meet NEMA 4 / IP65 requirements
Connectors	Single key 5 pin female 12mm (micro) connector or 25 pin sub-D female

CONFIGURATION DATA

The maximum number of modules connected to the discrete I/O side is 8. A fully configured manifold assembly would require 2 master modules with 6 slaves.



G2-1 Electronics

How to Order

1) Assembly Kit Selection

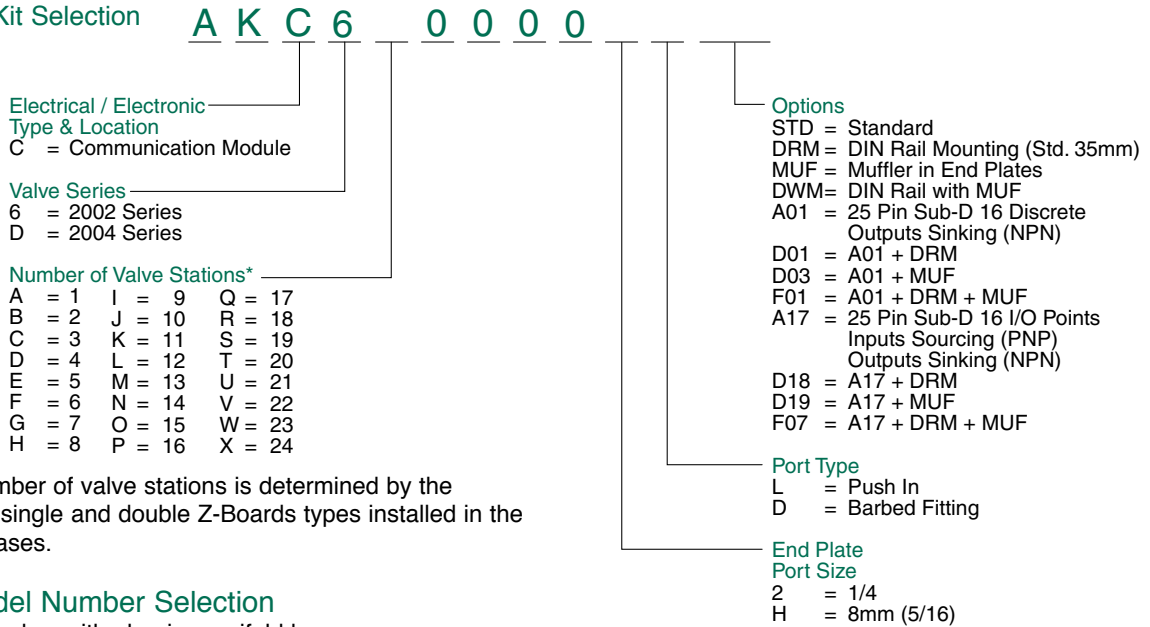

* Maximum number of valve stations is determined by the combination of single and double Z-Boards types installed in the manifold sub-bases.

2) Valve Model Number Selection

Valve model number with plug-in manifold base.

3) Electronic Interface

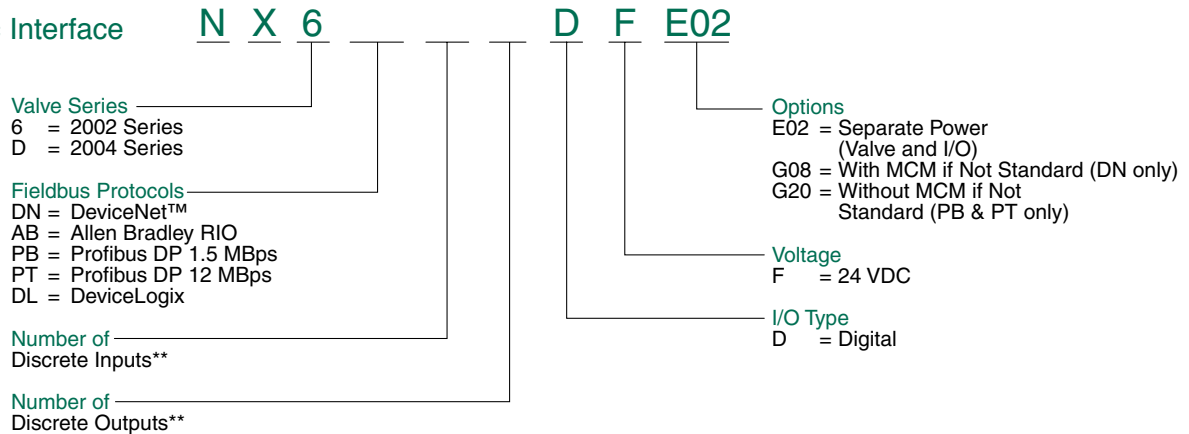

**4) I/O Per I/O Station – Electronic Interface Option Only (See I/O table below)

When ordering up to eight (8) I/O you must order one (1) Master I/O (which contains two (2) points I/O itself). The balance required is made up of Slaves, two (2) points per I/O station (total 3 Slave modules). A maximum of sixteen (16) I/O points can be configured by using two (2) Master modules and six (6) Slave modules. Total number of discrete inputs plus total number of discrete outputs must be less than or equal to 16. (See I/O table below).

Input master modules can be used with Output Slave Modules.

Output master Modules can be used with Input Slave Modules.

Sub-D outputs and I/O types do not require additional master modules when used alone

I/O Table: Note 2 I/O per station

HOUSING TYPE	SINKING (NPN) OUTPUT	SINKING (NPN) or SOURCING (PNP) INPUT
Master Kit No.	239-1800	239-1802
Slave Kit No.	239-1801	239-1803



G2-1 Electronics

AKC Communication Module

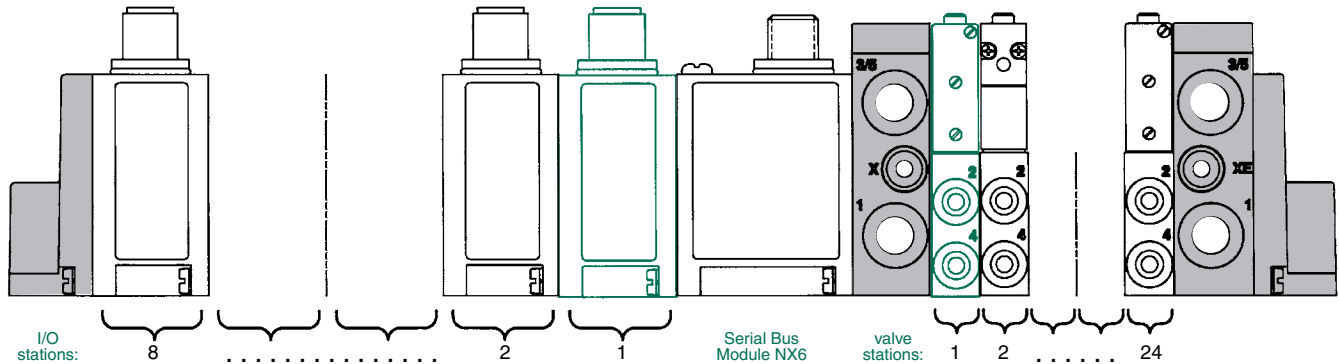

- Shaded components described by Assembly Kit (AK) model number designation (see #1, pg. 8), with the exception of the Communication module and number of I/O stations that are described by Electronic Interface (NX6) model number designation. (see #3, pg. 8)
- Each valve manifold station is listed in sequential order from left to right when facing the port side of the manifold as indicated.
- Each discrete I/O station is listed in sequential order from RIGHT to LEFT starting from the Communication module as indicated.

NOTE: I/O stations #1 and #5 (if required) must always be a MASTER KIT. (see #4, pg. 8)

Stations 2,3,4,6,7 and 8 must be either input or output Slave kits.

NOTE: Total of 24 solenoid outputs available for 2002 Series. Either 24 single solenoid valves or 12 double solenoid valves or any combination of singles or doubles, not to exceed 24 solenoid outputs for AKC Serial/Bus are allowed.

NOTE: Total of 16 solenoid outputs available for 2004 Series.

- Example order:
- AKC6D00002LSTD
 - 021BW4Z3MK00061
 - 021BW4Z3MK00061
 - 021BB4Z4MK00061
 - 021BB4Z4MK00061
 - NX6DN0808DFE02
- I/O station 1 239-1802Input Master Sinking (NPN) Kit
 - I/O station 2 239-1803Input Slave Sinking (NPN) Kit
 - I/O station 3 239-1803Input Slave Sourcing (PNP) Kit
 - I/O station 4 239-1803Input Slave Sourcing (PNP) Kit
 - I/O station 5 239-1800Output Master Sinking (NPN) Kit
 - I/O station 6 239-1801Output Slave Sinking (NPN) Kit
 - I/O station 7 239-1801Output Slave Sinking (NPN) Kit
 - I/O station 8 239-1801Output Slave Sinking (NPN) Kit
- ASSEMBLED

LH Mounting Cover Kit

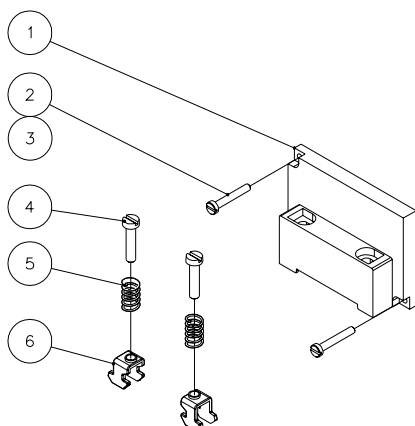

DET. NO.	NO. REQ'D	PART NAME	PART NO.
1	1	LH DIN Rail Mtg Cover	105-381
2	2	Screw	127-844
3	2	Lockwasher	128-192
4	2	Screw	127-472
5	2	Spring	115-355
6	2	Clamp	125-720

LH MOUNTING COVER KIT	PART NO.
With DIN Rail	239-1819
Without DIN Rail	239-1820



Fieldbus Communication Module and Manual Configuration Module Assemblies

Communication Module

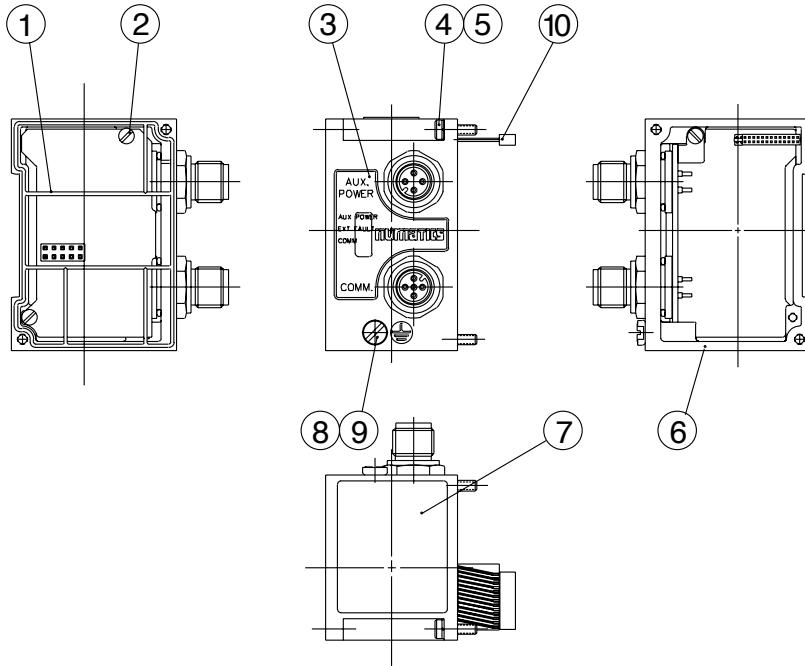

DET. NO.	NO. REQ'D	PART NAME	PART NO.
1	1	Gasket	113-503
2	3	Screw	127-794
3	1	Nameplate (DeviceNet)	122-1122
3	1	Nameplate (Profibus)	122-1123
3	1	Nameplate (Allen Bradley RIO)	122-1124
4	2	Screw	127-795
5	2	Lockwasher	128-192
6	1	Housing	125-1017
7	1	Nameplate	122-1058
8	1	Screw	127-176
9	1	Cup Washer	128-162
10	1	Transfer Board (2002)	256-589
	1	Transfer Board (2004)	256-552

Communication Module Kits (w/o End Plates)

DESCRIPTION	PART NO.	
	2002	2004
AB 1771 RIO	239-1804	239-1807
AS-i	Consult Factory	Consult Factory
CANopen	Consult Factory	Consult Factory
DeviceLogix	239-2108	Consult Factory
DeviceNet	239-1794	239-1684
Profibus 1.5 Mbps	239-1805	239-1808
Profibus 12 Mbps	239-1806	239-1809

Manual Configuration Module (MCM)

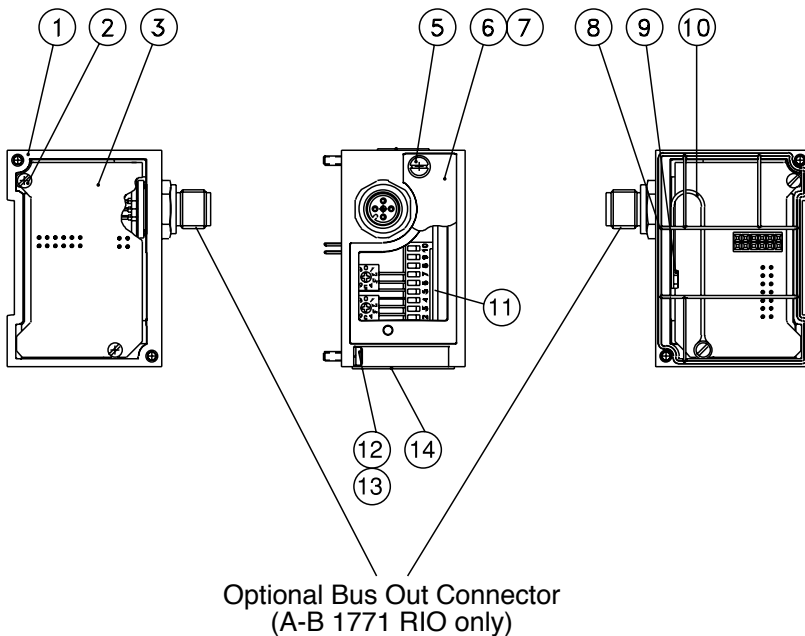

DET. NO.	NO. REQ'D	PART NAME	PART NO.
1	1	Switch Housing w/ conn.	125-800
1	1	Switch Housing w/o conn.	125-1038
2	4	Screw	127-794
5	2	Screw	127-852
6	1	Cover w/ conn.	105-399
6	1	Cover w/o conn.	105-384
7	1	Gasket w/conn.	113-529
7	1	Gasket w/o conn.	113-508
8	1	Gasket	113-503
9	1	Screw	127-172
10	1	Cover Strap	125-772
12	2	Screw	127-795
13	2	Lockwasher	126-192
14	1	Nameplate (Conn Ver. Only)	122-1058

Manual Configuration Module Kits (w/o End Plates)

DESCRIPTION	PART NO.
With Connector (A-B 1771 RIO only)	239-1812
Without Connector	239-1813



G2-1 Electronics

I/O Modules Assemblies

I/O Module Kit with Input LED Indicator (2 I/O per module)

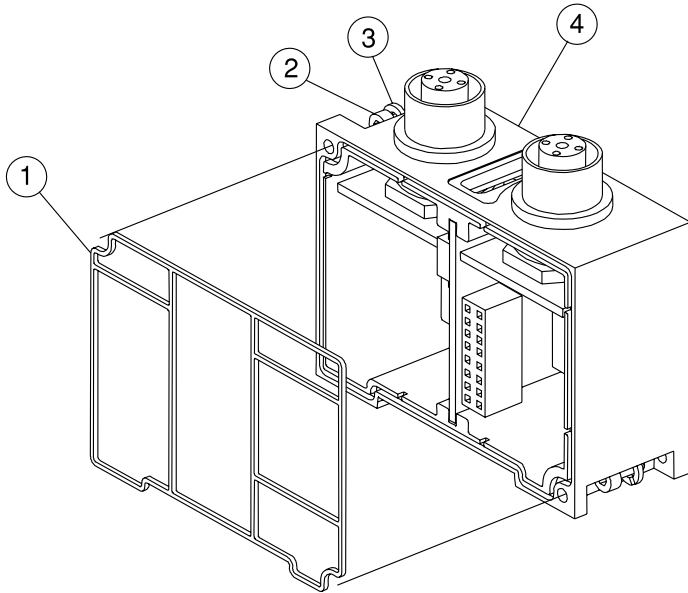

DET. NO.	NO. REQ'D	PART NAME	PART NO.
1	1	Gasket	113-503
2	2	Screw	127-795
3	2	Lockwasher	128-192
4	1	Housing	125-807

HOUSING TYPE	OUTPUT
Master Kit No.	
Output - Sinking (NPN)	239-1800
Input - Sinking (NPN) or Sourcing (PNP)	239-1802
Slave Kit No.	
Output - Sinking (NPN)	239-1801
Input - Sinking (NPN) or Sourcing (PNP)	239-1803
Connector Type	
I/O	12 mm (Micro) 5 Pin Female

25 Pin Female Sub-D Discrete Output and I/O Module

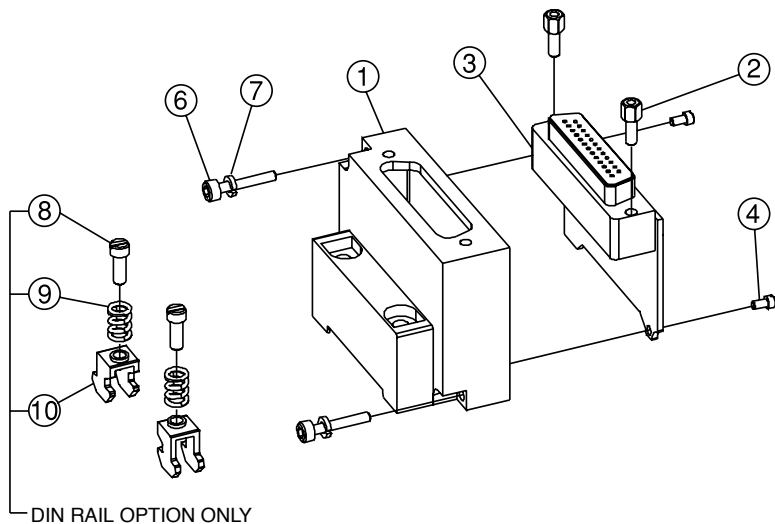

DET. NO.	NO. REQ'D	PART NAME	PART NO.
1	1	Housing	105-379
2	2	Hex Screw	127-825
3	1	Gasket	113-507
4	2	Screw	127-794
6	1	Nameplate	122-1057
7	2	Screw	127-499
8	2	Lockwasher	128-192
9	2	Screw (w/DIN)	127-472
10	2	Spring (w/DIN)	115-355
11	2	Clamp (w/DIN)	125-720

Discrete output and I/O Module Kit

DESCRIPTION	PART NO.
16 pt. Output Sinking (NPN) with DIN Rail	239-1225
16 pt. Output Sinking (NPN) w/o DIN Rail	239-1221
16 pt. Input Sourcing (PNP) and/or Output Sinking (NPN) with DIN Rail	239-1866
16 pt. Input Sourcing (PNP) and/or Output Sinking (NPN) w/o DIN Rail	239-1865

Note: When ordering this module in an assembled manifold "AK" use the corresponding option code in the "AK" model number. Do not list the module part number under the Electronic Interface model number "NX".



G2-1 Electronics

FlexiBlok® Manifold with Fieldbus Electronics Dimensional Drawing

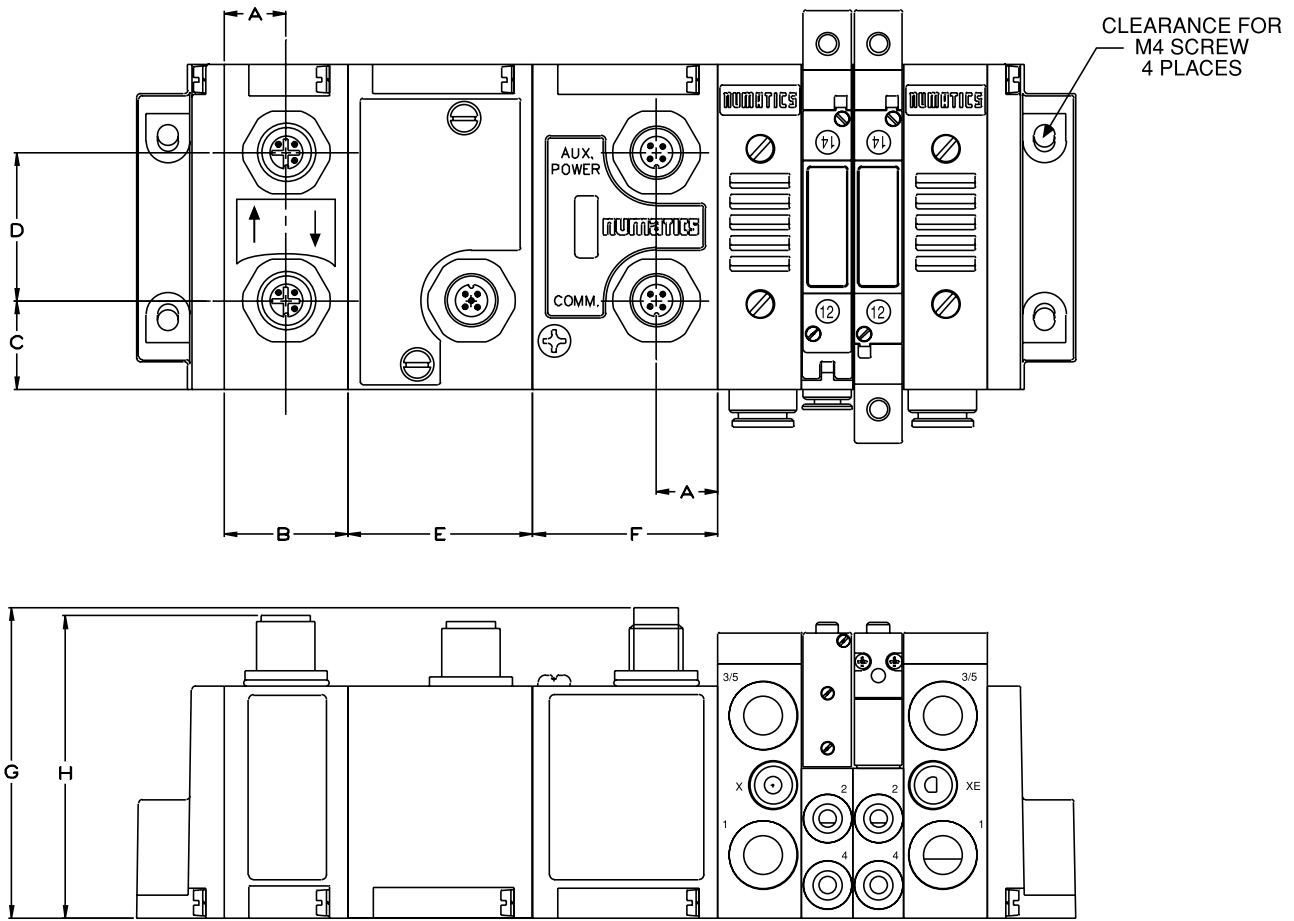

Dimensions

top dimensions = inches
bottom dimensions (in parenthesis) = millimeters

A	B	C	D	E	F	G	H
0.50 (12.7)	1.00 (25.4)	0.72 (18.3)	1.20 (30.5)	1.50 (38.1)	1.50 (38.1)	2.38 (60.5)	2.32 (59.0)

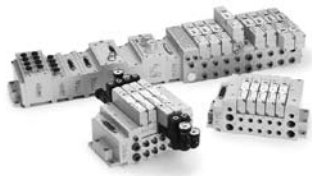

G2-2 Fieldbus Communications Electronics

Why use Numatics Fieldbus communication electronics? **Modular Reality**

- No internal wiring simplifies assembly
- Up to 192 discrete output points plus 32 valve solenoids and 96 input points per communication mode
- Enhanced diagnostics include discrete I/O status with short circuit protection
- Software or manual configuration simplifies commissioning
- Plug-together flexibility allows modularity and scalability
- Backplane technology allows fast maintenance
- Conformance tested ensures compatibility
- Shorted and open load diagnostics
- NPN and PNP discrete I/O modules
- NEMA 4/IP65 protected against water splash
- Low cost distribution options provide economic solutions for applications
- DIN rail mountable

Supported Protocols:

- Allen Bradley 1771 Remote I/O
- AS-i
- CANopen
- ControlNet
- DeviceNet
- DeviceNet with DeviceLogix
- EtherNet/IP
- FIPIO
- Interbus-S
- Modbus/TCP
- Profibus DP 1.5 MBps & 12MBps
- DeviceNet with Quickconnect

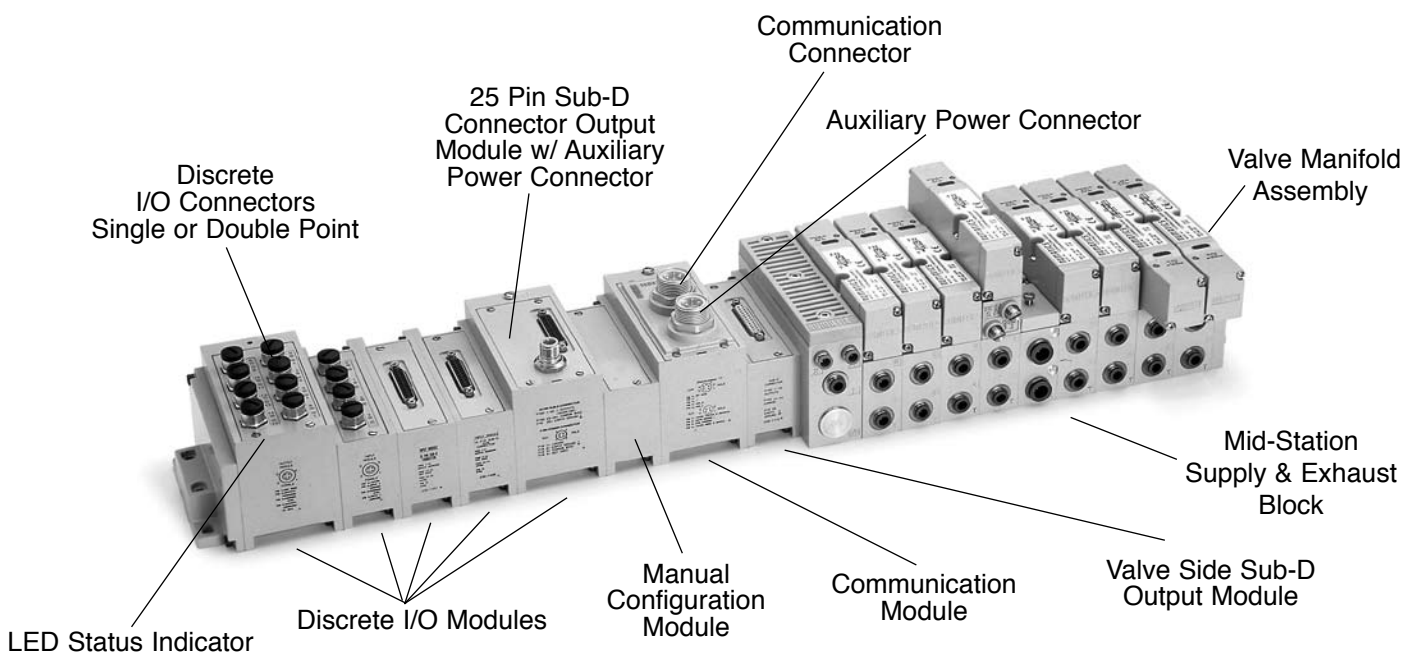



Allen Bradley 1771 Remote I/O

Allen-Bradley 1771 Remote I/O is a proprietary protocol based on a patented chipset. This chipset is obtained from Allen-Bradley and incorporated into the Numatics RIO module.

Numatics G2-2 Communications Node is capable of addressing up to 1 full rack of I/O.

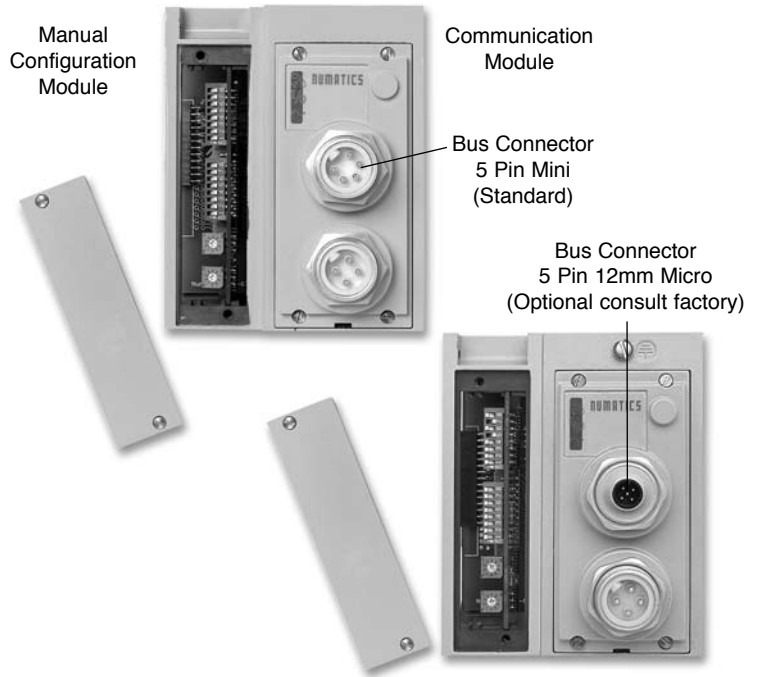

Technical Data

ELECTRICAL DATA	VOLTAGE	CURRENT
Node Power	24 VDC ±	0.065 amps.
Valve & Discrete I/O	24 VDC +/- 10%	8 amps. maximum
Aux Power Connector	Single key 4 pin mini type	
Communication Connector	Single key 5 pin (Mini or Micro type) male	
LED's	Communications status, Fuse integrity and Aux. power status	
OPERATING DATA		
Temperature Range	-10° to +115° F (-23° to +46° C)	
Humidity	95% relative humidity, non-condensing	
Moisture	Designed to meet NEMA 4 / IP65 requirements	
CONFIGURATION DATA		
Communication Module	Contains all communication electronics as well as short circuit protected driver circuitry for up to 32 valve solenoids.	
Manual Configuration Module (MCM)	Module containing DIP and rotary switches for setting device configuration data.	
Maximum Valve Solenoid Outputs	32	
Maximum Discrete I/O Points	Various combinations of 110 outputs & 80 inputs	
Rack Size:	Rack size set automatically to 1/4, 1/2, 3/4, or full rack based on the I/O modules installed on the manifold assembly.	
NETWORK DATA		
Supported Baud Rates	57.6 K Baud, 115.2 K Baud and 230.4 K Baud	
Bus Connector	Single keyway 5 pin mini or 12mm micro type	
Special Features	Support for processor restart/lockout and hold last state	

This product incorporates technology which is licensed by Allen- Bradley Company, Inc. Allen-Bradley has not technically approved, nor does it warrant or support this product. All warranty and support for this product and its application is provided solely by Numatics, Incorporated.



G2-2 Electronics

AS-i

AS-Interface (AS-i) is a simple bit level networking solution for actuators and sensors in manufacturing systems. It is an open technology supported by over 100 vendors worldwide, guaranteeing best-in-class solutions.

AS-i nodes are capable of addressing up to 4 input and 4 output points in standard mode or 4 inputs and 3 outputs in extended mode. Numatics' AS-i offering allows 4 nodes to be placed in one manifold, thus allowing up to 16 inputs and 16 valve solenoid coils on a single manifold.

For more information on AS-i visit the AS-i trade organization at www.as-interface.com



Technical Data

ELECTRICAL DATA	VOLTAGE	CURRENT
BUS Power	26.5 – 31.6 VDC	0.023 amps. per node
Valve Power	24 VDC +/- 10%	
Aux Power Connector	"AS-i cable clamp" IDC connector	
Communication Connector	"AS-i cable clamp" IDC connector	
LED's	External Power, Bus Power and Error	
OPERATING DATA		
Temperature Range	-10° to +115° F (-23° to +46° C)	
Humidity	95% relative humidity, non condensing	
Moisture	Designed to meet NEMA 4 / IP65 requirements	
CONFIGURATION DATA		
Communication Module	Contains all communication electronics as well as short circuit protected driver circuitry for up to 16 valve solenoids and 16 inputs. AS-i nodes available with standard or enhanced addressing modes.	
Maximum Valve Solenoid Outputs	16 (with 4 AS-i nodes with standard addressing); 12 (with extended addressing)	
Maximum Discrete I/O Points	16 inputs (with 4 AS-i nodes with standard addressing); 16 (with extended addressing)	
NETWORK DATA		
Bus Connector	"AS-i cable clamp" IDC connector	

Electronic Data Sheet (EDS) file and technical manuals are available in the download section of the Numatics, Inc. web site at: www.numatics.com/fieldbus



CANopen

CANopen is an open protocol based on Controller Area Network (CAN). It was designed for motion oriented machine control networks but has migrated to various industrial applications. CAN in Automation (CiA) is the international users' and manufacturers' organization that develops and supports CAN-based protocols. More information regarding this organization can be found at www.can-cia.org



Technical Data

ELECTRICAL DATA		VOLTAGE	CURRENT
Node Power		24 VDC +/- 10%	0.040 amps.
Bus Power		11-25 VDC	0.025 amps.
Valve & Discrete I/O		24 VDC +/- 10%	8 amps. maximum
Aux Power Connector	Single key 4 pin MINI type (male)		
Communication Connector	Single key 5 pin micro (12mm) type (male)		
LED's	Module Status, Network Status, Fuse integrity and Auxiliary power status		
OPERATING DATA			
Temperature Range	-10° to +115° F (-23° to +46° C)		
Humidity	95% relative humidity, non condensing		
Moisture	Designed to meet NEMA 4 / IP65 requirements		
CONFIGURATION DATA			
Communication Module	Contains all communication electronics as well as short circuit protected driver circuitry for up to 32 valve solenoids		
Manual Configuration Module (MCM)	Module containing DIP and rotary switches for setting device configuration data. Comes standard with communication module		
Maximum Valve Solenoid Outputs	32		
Maximum Discrete I/O Points	Various Combinations of 160 outputs and 80 inputs		
NETWORK DATA			
Supported Baud Rates	125K, 250K, 500K and 1M		
Bus Connector	Single key 5 pin micro (12mm) type (male)		
Diagnostics	Shorts and open load conditions from valve solenoid coils & outputs are monitored		

Electronic Data Sheet (EDS) file and technical manuals are available in the download section of the Numatics, Inc. web site at: www.numatics.com/fieldbus

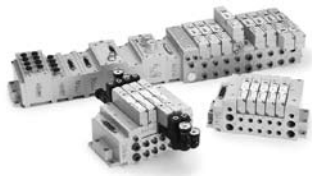

ControlNet

ControlNet is an open network that meets the demands of today's industrial applications requiring high speed (5 MBIT/sec.), high throughput with predictable and repeatable transfers of mission critical data.

Originally developed by Allen-Bradley, it is based on the Control and Information Protocol (CIP) technology. The governing body for the ControlNet technology is ControlNet International LTD.

More information about ControlNet can be obtained from the following website:
www.controlnet.org



Technical Data

ELECTRICAL DATA	VOLTAGE	CURRENT
Node Power	24V ± 10%	0.097 amps.
Valve & Discrete I/O	24 VDC +/- 10%	8 amps. maximum
Aux Power Connector	Single key 4 pin mini type (male)	
LED's	Module owned, Module status, Channel A & B, Fuse integrity & Aux power status	
Communication Connector	BNC Type	

OPERATING DATA	
Temperature Range	-10° to +115° F (-23° to +46° C)
Humidity	95% relative humidity, non-condensing
Moisture	Designed to meet NEMA 4 / IP65 requirements with proper connector hoods

CONFIGURATION DATA	
Power Module	Contains power interface electronics as well as short circuit protected driver circuitry for up to 32 valve solenoids.
Comm. Interface Module	Contains communication interface electronics and network address (MAC ID) configuration hardware.
Maximum Valve Solenoid Outputs	32
Maximum Discrete I/O Points	Various combinations of 192 outputs & 96 inputs

NETWORK DATA	
Supported Baud Rates	5 MBIT/sec
Connectors	BNC type for network; RJ-45 for Network Access Point (NAP)
Diagnostics	Shorts & open load conditions from valve solenoid coils & outputs are monitored
Special Features	Support for redundant media via 2 BNC connectors

Electronic Data Sheet (EDS) file and technical manuals are available in the download section of the Numatics, Inc. web site at: www.numatics.com/fieldbus



DeviceLogix

DeviceLogix is a Rockwell Automation technology that allows a DeviceNet node to be programmed to execute a sequence independently from the control for the main PLC/IPC. A DeviceLogix enabled DeviceNet node can be used in conjunction with a standard DeviceNet network, providing simple distributed control functionality. Additionally, it can also be used in a standalone application, without a network connection or PLC/IPC, to sequence pneumatic valves and control I/O. Numatics has integrated this licensed technology into its DeviceNet compatible valve manifold series, which combine the functionality of a modular pneumatic valve system with integrated I/O.

Programming of the DeviceLogix enabled node is done using the industry standard DeviceNet commissioning software tool RSNetwork for DeviceNet for Rockwell Automation. The programming software features an easily understandable graphics environment where the users can simply “drag and drop” logic function blocks (i.e. AND, NAND, OR, NOR, XOR, XNOR, RS LATCHES, COUNTERS and TIMERS) onto a page and interconnect them to develop the required sequence, or ladder logic programming can be used to develop a sequence. The programmed sequence is downloaded to the node via the standard DeviceNet communication connection, thus multiple nodes can be programmed simultaneously on the same network.



Technical Data

ELECTRICAL DATA		VOLTAGE	CURRENT
Node Power		24 VDC +/- 10%	
Bus Power		11-25 VDC	0.025 amps
Valve & Discrete I/O		24 VDC +/- 10%	8 amps. maximum
Aux Power Connector		Single key 4 pin mini type (male)	
Communication Connector		Single key 5 pin (Mini type) male	
LED's		Module status, Network status, Auxiliary power status, Fuse integrity and Logic enabled.	
OPERATING DATA			
Temperature Range		-10° to +115°F (-23° to +46°C)	
Humidity		95% relative humidity, non-condensing	
Moisture		Designed to meet NEMA 4 / IP65 requirements	
CONFIGURATION DATA			
Comm. Interface Module		Contains all communication and control electronics as well as short circuit protected driver circuitry for up to 32 valve solenoids	
Maximum Valve Solenoid Outputs		32	
Maximum Discrete I/O Points		Various combinations of up to 80 outputs & 96 inputs; logical limit of 72 function block	
NETWORK DATA			
Supported Baud Rates		125 K Baud, 250 K Baud and 500 K Baud with auto-baud detection	
Connectors		Single key 5 pin mini or 12mm micro type (male)	
Diagnostics		Shorts and open load conditions from valve solenoid coils and outputs are monitored	
Special Features		Does not require a network connection for stand-alone applications	
Electronic Data Sheet (EDS) file and technical manuals are available in the download section of the Numatics, Inc. web site at: www.numatics.com/fieldbus			

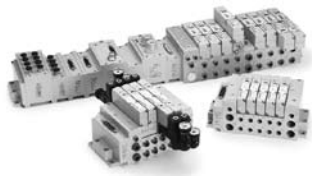

G2-2 Electronics

DeviceNet

DeviceNet is an open protocol bus communication system developed by Allen-Bradley based on Controller Area Network (CAN) technology. The governing body for DeviceNet is the Open DeviceNet Vendors Association (ODVA). The ODVA controls the DeviceNet specification and oversees product conformance testing.

Numatics G2-2 DeviceNet nodes are capable of addressing up to 192 output/96 input. They have been tested and approved for conformance by the ODVA.

More information about DeviceNet and the ODVA can be obtained from the following WEB site:
 Open DeviceNet Vendors Association (ODVA)
www.odva.org

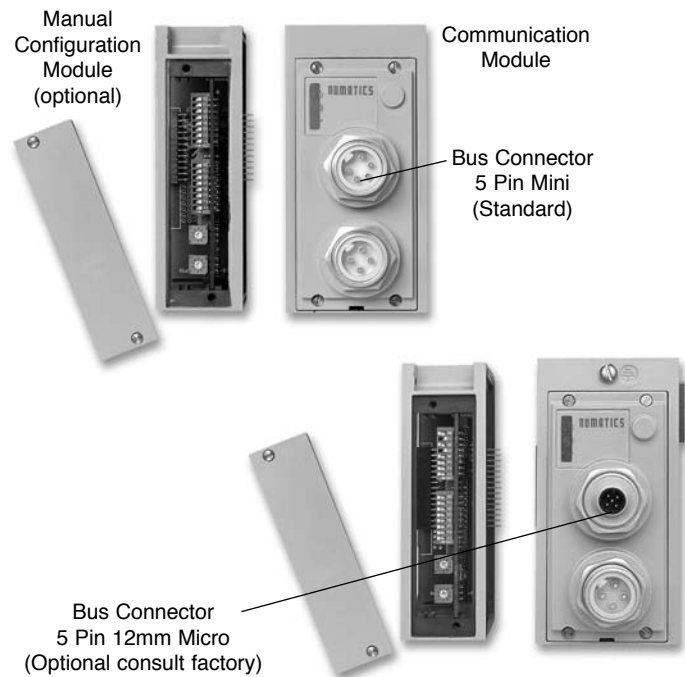

Technical Data

ELECTRICAL DATA	VOLTAGE	CURRENT
Node Power	24V ± 10%	0.040 amps.
BUS Power	11-25 VDC	0.025 amps.
Valve & Discrete I/O	24 VDC +/- 10%	8 amps. maximum
Aux Power Connector	Single key 4 pin mini type (male)	
Communication Connector	Single key 5 pin (Mini or Micro type) male	
LED's	Module status, Network status, Fuse integrity & Aux power status	
OPERATING DATA		
Temperature Range	-10° to +115° F (-23° to +46° C)	
Humidity	95% relative humidity, non-condensing	
Moisture	Designed to meet NEMA 4 / IP65 requirements	
CONFIGURATION DATA		
Communication Module	Contains all communication electronics as well as short circuit protected driver circuitry for up to 32 valve solenoids.	
Manual Configuration Module (MCM)	Optional module containing DIP and rotary switches for setting device configuration data. Note: Use option "G08" in "NX" model number	
Maximum Valve Solenoid Outputs	32	
Maximum Discrete I/O Points	Software configurable (standard): Various combinations of 192 outputs & 96 inputs With optional manual configuration module: Various combinations of 160 outputs & 80 inputs	
NETWORK DATA		
Supported Baud Rates	125 K Baud, 250 K Baud, 500 K Baud with Auto-Baud detection	
Supported Connection Types	Polled, Cyclic, Change of State (COS) and Combination Message Capability	
Bus Connector	Single keyway 5 pin mini or 12mm micro types (male)	
Diagnostics	Shorts & open load conditions from valve solenoid coils & outputs are monitored	
Special Features	Supports Auto-Device Replacement (ADR)	

Electronic Data Sheet (EDS) file and technical manuals are available in the download section of the Numatics, Inc. web site at: www.numatics.com/fieldbus



DeviceNet Quickconnect

Numatics G2-2 DeviceNet nodes are capable of addressing various combinations of up to 192 outputs and 96 inputs. They have been tested and approved for conformance by ODVA.

The DeviceNet with QuickConnect feature allows a reconnected Numatics G2-2 node on a DeviceNet network to quickly go into operation by shortening the time required to make the logical connection between the node and the scanner. This feature has benefits in many applications including those needing to make on the fly tool changes.

DeviceNet is an open protocol bus communication system by Allen-Bradley based on Controller Area Network (CAN) technology. The governing body for DeviceNet is the Open DeviceNet Vendors Association (ODVA). The ODVA controls the DeviceNet specification and oversees product conformance testing.

More information about DeviceNet and the ODVA can be obtained from www.odva.org

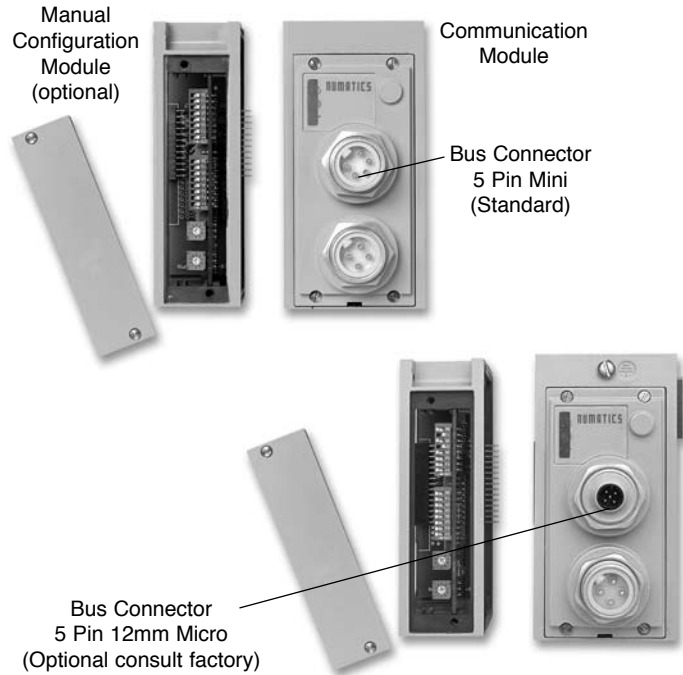

Technical Data

ELECTRICAL DATA	VOLTAGE	CURRENT
Node Power	24 VDC +/- 10%	0.040 amps.
Bus Power	11-25 VDC	0.025 amps.
Valve & Discrete I/O	24 VDC +/- 10%	8 amps. maximum
Aux Power Connector	Single key 4 pin MINI type (male)	
Communication Connector	Single key 5 pin MINI or 12mm micro type (male)	
LED's	Module Status, Network status, Fuse integrity and Auxiliary power status	
OPERATING DATA		
Temperature Range	-10° to +115° F (-23° to +46° C)	
Humidity	95% relative humidity, non condensing	
Moisture	Designed to meet NEMA 4 / IP65 requirements	
CONFIGURATION DATA		
Communication Module	Contains all communication electronics as well as short circuit protected driver circuitry for up to 32 valve solenoids	
Manual Configuration Module (MCM)	Optional module containing DIP and rotary switches for setting device configuration data. Note: Use option G08 in "NX" model number	
Maximum Valve Solenoid Outputs	32	
Maximum Discrete I/O Points	Various Combinations of 160 outputs and 80 inputs	
NETWORK DATA		
Supported Baud Rates	125K, 250K, 500K and Autobaud	
Supported Connection Types	Polled, Cyclic, Change of State (COS) and Combination Message Capability	
Bus Connector	Single key 5 pin MINI or 12mm micro type (male)	
Diagnostics	Shorts and open load conditions from valve solenoid coils & outputs are monitored	
Special Features	Supports Auto-Device Replacement (ADR)	

Electronic Data Sheet (EDS) file and technical manuals are available in the download section of the Numatics, Inc. web site at: www.numatics.com/fieldbus



G2-2 Electronics

Ethernet

Ethernet, used throughout the world to network millions of PC's has now evolved into a viable industrial network. Ethernet is an open architecture high-level communication network that meets the demands of today's industrial applications requiring high-speed (10/100 Mbit/s), high-throughput and flexibility. Various application layers for this protocol include **TCP/IP**, **EtherNet/IP**, and **Modbus TCP/IP**. Additionally, Ethernet technology can integrate an on-board Web Server, which can make the node readily accessible to any standard Web browser for configuration, testing and even retrieval of technical documentation. E-mail capability allows the manifold to send e-mails that are triggered from specific events ranging from diagnostic information to automatic Preventative Maintenance scheduling. Numatics has integrated this technology into the G2-2 series of fieldbus manifolds, which combines the functionality of a scalable modular I/O system with a modular pneumatic valve manifold.



Technical Data

ELECTRICAL DATA	VOLTAGE	CURRENT
Node Power	24 VDC +/- 10%	
Valve & Discrete I/O	24 VDC +/- 10%	
Aux Power Connector	Single key 4 pin mini type (male)	
LED's	Module status, Link, active, Net status, Auxiliary power status and Fuse integrity	
OPERATING DATA		
Temperature Range	-10° to +115°F (-23° to +46°C)	
Humidity	95% relative humidity, non-condensing	
Moisture	Designed to meet NEMA 4 / IP65 requirements	
CONFIGURATION DATA		
Power Module	Contains all power interface electronics as well as short circuit protected driver circuitry for up to 32 valve solenoids	
Comm. Interface Module	Contains all communication interfaced electronics	
Maximum Valve Solenoid Outputs	32	
Maximum Discrete I/O Points	Various combinations of up to 192 outputs & 96 inputs	
NETWORK DATA		
Supported Baud Rates	10 Mbit / 100 Mbit	
Connectors	RJ45 & M12 with "D Coding"	
Diagnostics	Shorts and open load conditions from valve solenoid coils and outputs are monitored	
Special Features	Integrated web server and e-mail capabilities	



Foundation Fieldbus H1 (FF H1)

Foundation Fieldbus H1 is an open protocol governed by the Fieldbus Foundation™. Intended primarily for process control applications, it is designed to easily integrate field level devices such as transmitters and actuators over a digital communication network running at 31.25 Kbit/s.

The General Purpose I/O (GPIO) mode of this communication module can control up to 32 digital Inputs and 16 digital Outputs. Outputs can be any combination of the integrated manifold's valve coils and discrete output modules. This mode is perfect for automating process valves over an FF network where enhanced diagnostics are not required.

The Valve Monitoring System (VMS) function of this mode emulates 8 separate FF enabled valve position indicators. This function has the ability of automating 8 process valves over 1 FF node while retaining the complete diagnostic capability of 8 separate FF nodes. Enhanced diagnostic capability of this function allows automatic monitoring of Travel Times, Break Times, Lost Position, Cycle counter and Auto Calibration.

GPIO and VMS functionality can coexist on the same manifold. The maximum digital I/O count is 32 Inputs and 16 Outputs. VMS functionality allocates 2 digital Inputs to every valve station so a maximum of 8 valves and 16 inputs are allowed with this function. The remainder can be allocated as GPIO.

The optional "Logic Transducer" mode allows user to write local logic to be executed independent of DCS.

NOTE: When specifying valve position indication as inputs into the valve manifold input module use gold contact mechanical switches. ASCO VMS switch code "H2" signifying 2 mechanical SPDT gold contact switches.

Example: HS2D1YCH2NGA

<http://www.ascovalve.com/Applications/Products/PositionIndicators.aspx>



Technical Data

ELECTRICAL DATA	VOLTAGE	CURRENT
Node Power	24 VDC +/- 10%	
Bus Power	9-32 VDC	12.5 mA
Valve & Discrete I/O	24 VDC +/- 10%	8 amps. maximum
Aux Power Connector	Single key 5 pin MINI type (male)	
Communication Connector	Single key 4 pin MINI type (male)	
LED's	Comm. status, Auxiliary power status, Fuse integrity.	
OPERATING DATA		
Temperature Range	-10° to +115°F (-23° to +46°C)	
Humidity	95% relative humidity, non-condensing	
Moisture	Designed to meet NEMA 4 / IP65 requirements	
CONFIGURATION DATA		
Comm. Interface Module	Contains all communication and control electronics as well as short circuit protected driver circuitry for up to 16 valve solenoids	
Maximum Valve Solenoid Outputs	16	
Maximum Discrete I/O Points	32 Inputs / 16 Outputs (Valve coils are assigned prior to discrete Outputs)	
NETWORK DATA		
Supported Baud Rates	31.25 kbit/s	
Connectors	Single key 4 pin MINI type (male)	
Diagnostics	Shorts and open load conditions from valve solenoid coils and I/O are monitored	
Special Features	Supports Link Active Scheduler (LAS) and available with optional Logic Transducer mode	

Electronic Data Sheet (DD) file and technical manuals are available in the download section of the Numatics, Inc. web site at: www.numatics.com/fieldbus



FIPIO

The FIPIO fieldbus is a standard protocol used to communicate between different control system components. It enables a maximum of 256 devices to be connected at the connection point integrated in the processor. This fieldbus conforms to the WorldFip standard based on producer/consumer mechanisms. It is designed to support both deterministic data-transfer and also random messaging.



Technical Data

ELECTRICAL DATA		VOLTAGE	CURRENT
Node Power		24 VDC +/- 10%	0.097 amps.
Valve & Discrete I/O		24 VDC +/- 10%	8 amps. maximum
Aux Power Connector		Single key 4 pin MINI type (male)	
Communication Connector		Single key 6 pin M23 type (male)	
LED's		Run, Error, I/O Comm., Fuse integrity and Auxiliary power status	
OPERATING DATA			
Temperature Range		-10° to +115° F (-23° to +46° C)	
Humidity		95% relative humidity, non condensing	
Moisture		Designed to meet NEMA 4 / IP65 requirements	
CONFIGURATION DATA			
Communication Module		Contains all communication electronics as well as short circuit protected driver circuitry for up to 32 valve solenoids	
Manual Configuration Module (MCM)		Contains communication interface electronics and network address configuration hardware.	
Maximum Valve Solenoid Outputs		32	
Maximum Discrete I/O Points		Various Combinations of 192 outputs and 96 inputs	
NETWORK DATA			
Supported Baud Rates		1 Mbit/s.	
Bus Connector		Single key 6 pin M23 type (male)	
Diagnostics		Shorts and open load conditions from valve solenoid coils & outputs are monitored	



Interbus - S

Interbus-S is an open architecture, high performing, ring based fieldbus system used in many of today's industrial network applications. I/O data is transmitted in frames that provide simultaneous and predictable updates to all devices on the network.

More Information about Interbus-S can be obtained at the following Interbus-S Club web site: www.ibsclub.com.



Technical Data

ELECTRICAL DATA	VOLTAGE	CURRENT
Node Power	24 VDC +/- 10%	
Valve & Discrete I/O	24 VDC +/- 10%	
Aux Power Connector	Single key 4 pin mini type (male)	
Communication Connector	9 pin Sub-D, Bus IN and Bus OUT	
LED's	TR, CC, RBDA, BA, Auxiliary power status and fuse integrity	
OPERATING DATA		
Temperature Range	-10° to +115° F (-23° to +46° C)	
Humidity	95% relative humidity, non-condensing	
CONFIGURATION DATA		
Power Module	Contains all power interface electronics as well as short circuit protected driver circuitry for up to 32 valve solenoids	
Comm. Interface Module	Contains all communication interfaced electronics	
Maximum Valve Solenoid Outputs	32	
Maximum Discrete I/O Points	Various combinations of up to 160 outputs & 96 inputs	
NETWORK DATA		
Supported Baud Rates	500 Kbit/s & 2 Mbit/s	
Connectors	Two 9 pin sub-d (1 male and 1 female)	
Diagnostics	Shorts and open load conditions from valve solenoid coils and outputs are monitored	

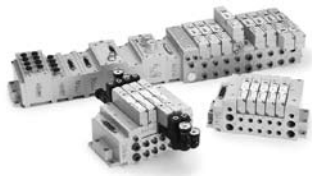

G2-2 Electronics

Profibus DP

Profibus DP is a vendor-independent, open fieldbus protocol designed for communication between automation control systems and distributed I/O at the device level.

Numatics' G2-2 Profibus DP nodes are capable of addressing up to 164 outputs/96 inputs. They are designed and tested to conform to the Profibus standard EN50170. Certification is by the Profibus Interface Center (PIC) according to the guidelines determined by the Profibus Trade Organization (PTO). The certification process ensures interoperability for all Profibus devices.

More information about Profibus DP can be obtained at the following web site:

Profibus Trade Organization (PTO)
www.profibus.com/

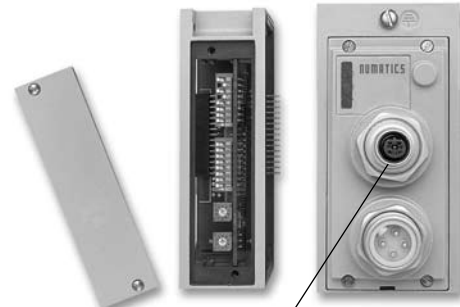

Bus Connector, 5 Pin 12mm Micro Reverse Keyway

Technical Data

ELECTRICAL DATA	VOLTAGE	CURRENT
Node Power	24 VDC +/- 10%	0.120 amps.
Valve & Discrete I/O	24 VDC +/- 10%	8 amps. maximum
Aux. Power Connectors	Single key 4 pin Mini connector	
Communication Connector	5 pin reverse key female (Micro) connector	
LED's	Processor status, Network status, Fuse integrity & Aux power status	
OPERATING DATA		
Temperature Range	-10° to +115° F (-23° to +46° C)	
Humidity	95% relative humidity, non-condensing	
Moisture	Designed to meet NEMA 4 / IP65 requirements	
CONFIGURATION DATA		
Communication Module	Contains all communication electronics as well as short circuit protected driver circuitry for up to 32 valve solenoids.	
Manual Configuration Module (MCM)	Module containing DIP and rotary switches for setting device configuration data. To order without MCM, use option G20 in NX model number. Optional only when using a Class 2 Profibus DP Master. (Note: see ordering options <i>page 27</i>)	
Maximum Valve Solenoid Outputs	32	
Maximum Discrete I/O Points	Manual configurable with MCM (standard): Various combinations of 160 outputs & 96 Inputs Software configurable (optional): Various combination of 192 outputs and 96 inputs	
NETWORK DATA		
Bus Connector	Single reverse key 5 pin 12mm micro (female)	
Diagnostics	Shorts & open load conditions from valve solenoid coils & discrete outputs are monitored	
Special Features	Supports Class 2 Profibus DP Master with auto-configuration, and fail-safe device settings	

(GSD) file and technical manuals are available in the download section of the Numatics, Inc. web site at: www.numatics.com/fieldbus



Discrete I/O Modules

Discrete I/O modules are used to connect additional I/O devices to the valve manifold node. This provides for more efficient use of system resources when configuring an industrial network.

Technical Data

ELECTRICAL DATA

Inputs:

Voltage	24 VDC
Type	NPN, PNP or contact closure
LED Indicator	Input status

Outputs:

Voltage	24 VDC +/- 10%
Current	0.5 amperes per output with short circuit protection (consult factory for higher current requirements)
Type	Sinking (NPN) & Sourcing (PNP)
LED Indicator	Output status

OPERATING DATA

Temperature Range	-10° to +115° F (-23° to +46° C)
Humidity	95% relative humidity, non-condensing
Moisture	Designed to meet NEMA 4 / IP65 requirements
Connectors	Single key 5 pin female 12mm (micro) 25 & 15 pin Sub-D or 19 Pin M23 circular connectors

CONFIGURATION DATA

The physical limitation of the discrete I/O section is 6 modules including the Manual Configuration Module.

	NARROW HOUSING				WIDE HOUSING			
Connectors per Block	4	4	1	2	8	8	1	2
I/O Points per Connector	1	2	16	8	1	2	22	16
Total I/O points	4	8	16	16	8	16	22	32

The maximum number of modules connected to the discrete I/O side is 6. A fully configured manifold assembly would require 6 Wide Profile Modules with double capacity per connector (i.e. 16 I/O points per module times 6 modules equals 96 I/O points). If a Manual Configuration Module is used (standard with A-B 1771 RIO & Profibus-DP), a maximum of five I/O modules may be installed and the maximum number of discrete I/O points is 80.

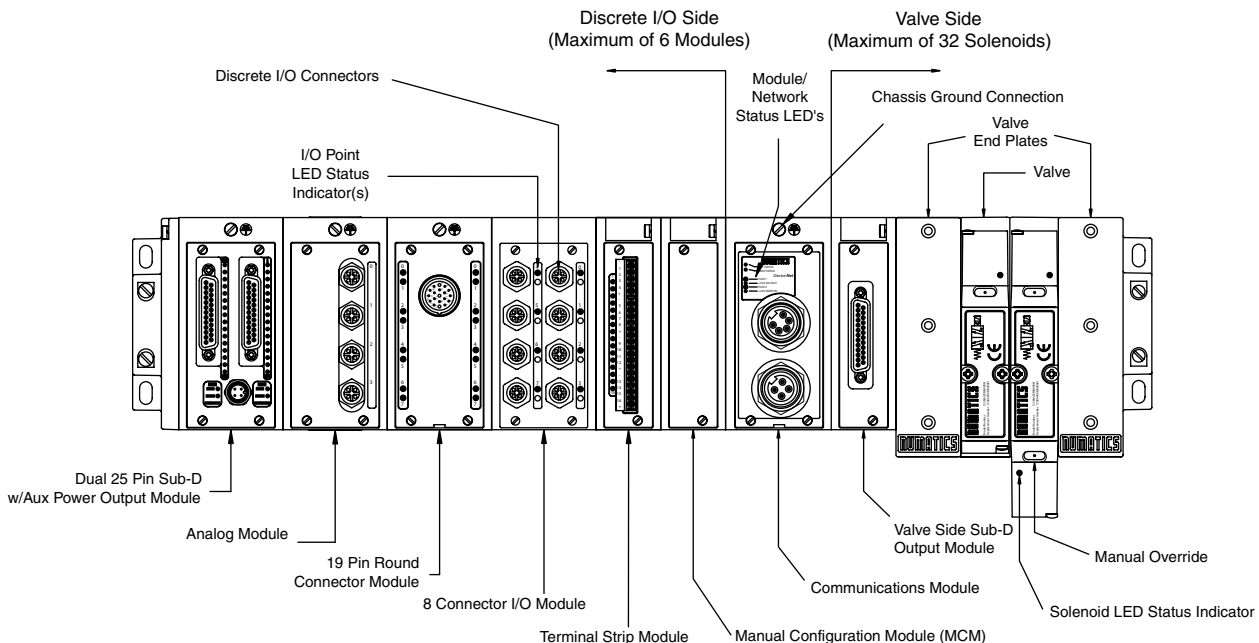

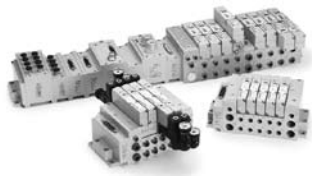

G2-2 Electronics

How to Order

1) Assembly Kit Selection

Each valve station must specify valve type and configuration.

2) Visit appropriate valve model section to specify each valve station.

A K C E D 0 0 0 0 3 L STD

Electrical / Electronic Type & Location

- C = Communication Module 2005, 2012 & 2035 Series or ISO 15407-2
- E = Communication Module ISO 1, 2 & 3 Series and 2002 Series
- V = Communication Module Mark 8, 15, 55 & 2009 Series

Valve Series

- B = 2035 Series
- E = 2005 or ISO 15407-2 18 mm
- 9 = 2009 Series
- G = 2012 or ISO 15407-2 26 mm
- H = Mark 8
- J = Mark 15
- M = Mark 55 Compact
- P = Mark 55 Fullsize
- Q = ISO 5599/2 Size 1
- R = ISO 5599/2 Size 2
- S = ISO 5599/2 Size 3
- 6 = 2002 Series

Number of Valve Stations*

- | | | | |
|-------|--------|--------|--------|
| A = 1 | I = 9 | Q = 17 | Y = 25 |
| B = 2 | J = 10 | R = 18 | Z = 26 |
| C = 3 | K = 11 | S = 19 | 2 = 27 |
| D = 4 | L = 12 | T = 20 | 3 = 28 |
| E = 5 | M = 13 | U = 21 | 4 = 29 |
| F = 6 | N = 14 | V = 22 | 5 = 30 |
| G = 7 | O = 15 | W = 23 | 6 = 31 |
| H = 8 | P = 16 | X = 24 | 7 = 32 |

*Maximum number of valve stations is determined by the combination of single and double Z-Boards types installed in the manifold sub-bases. All G2-2 communication modules support 32 output drivers for valve solenoid coils.

Options

- STD = Standard
- DRM = DIN Rail Mounting
- MUF = Muffler in End Plates
- DWM = DIN Rail with MUF
- A06 = End plate with ports on left end only, mounting plate only on right end
- D10 = A06 w/DIN Rail Mounting
- D11 = A06 w/Muffler in End Plates
- F05 = A06 w/DIN Rail with MUF
- 14X = External Pilot
- A05 = All Stations Wired as Doubles (AKV only)

Port Type

- L = Push In (2005 or 2012 only)
- N = NPTF
- G = Metric

End Plate Port Size

- 2** = 2012 and 2009
- 3** = 2012, 2005, Mark 8, ISO 5599/2 Size 1
- 4 = Mark 15 or ISO 5599/2 Size 2 & 2035
- 5 = Mark 55 Compact
- 6 = ISO 5599/2 Size 3
- 7 = Mark 55 Fullsize
- H** = 2012
- K** = 2005 or 2012
- ** See chart below

2005	2012
3 = 3/8	3 = Port Type G, N, or L
K = 10mm tube	Port 1 = 3/8 Port 3/5 = 1/2
	2 = Port Type L Only
	Port 1 = 1/4 Port 3/5 = 3/8
	H = Port Type L Only
	Port 1 = 8mm Port 3/5 = 12mm
	K = Port Type L Only
	Port 1 = 10mm Port 3/5 = 14mm



How to Order continued

3) Fieldbus Electronics

Valve model number with plug-in manifold base (see model selection tables for the valve type).

N X G DN 16 08 D F E02

Fieldbus Protocols

- AB = Allen Bradley RIO w/ MCM Standard
 - CN = ControlNet
 - CO = CANopen
 - DL = DeviceLogix
 - DN = DeviceNet™
 - DQ = DeviceNet w/ QuickConnect
 - EM = Modbus/TCP
 - EP = EtherNet/IP
 - FF = Foundation Fieldbus (FF H1)
 - FL = Foundation Fieldbus w/ Logic Transducer
 - FP = FIPIO
 - IS = Interbus-S
 - PT = Profibus DP w/ MCM Standard
- Note: For AS-i, see chart below.

Number of Discrete Inputs (See chart below if in excess of 99)

Number of Discrete Outputs (See chart below if in excess of 99)

Options

- E02 = Separate power standard (valve and I/O)
- G08 = With Manual Configuration Module (if not standard) & E02
- G10 = 12mm (Micro) Connector for Communications if Not Standard
- G15 = Required for Mark 8, 15, 55 & 2006 Ser
- G18 = Valve side Sub-D NPN output module
- G20 = Without Manual Configuration Module
- G22 = Dual 15 Pin Sub-D output module
- J03 = G15 plus Manual Configuration Module valve side
- J18 = Dual 25 Pin Sub-D output module valve side
- G26 = Cenelec Power Connection
- J23 = Cenelec Power Connection and MCM

Voltage

F = 24 VDC

I/O Type

- D = Digital
- A = Analog
- B = Analog and Digital

AS-i Table

STANDARD ADDRESSING	OUTPUTS	INPUTS
A1	4 Outputs	0 or 4
A2	8 Outputs	0, 4, or 8
A3	12 Outputs	0, 4, 8 or 12
A4	16 Outputs	0, 4, 8, 12 or 16
EXTENDED ADDRESSING	OUTPUTS	INPUTS
B1	3 Outputs	0 or 4
B2	6 Outputs	0, 4, or 8
B3	9 Outputs	0, 4, 8 or 12
B4	12 Outputs	0, 4, 8, 12 or 16

Note: AS-i can have a maximum of 16 discrete inputs and 0 discrete outputs.

3.) Discrete I/O Table for I/O In Excess of 99

I/O CODE	NUMBER OF I/O	I/O CODE	NUMBER OF I/O	I/O CODE	NUMBER OF I/O	I/O CODE	NUMBER OF I/O
A0	100	B0	110	C0	120	D0	130
A1	101	B1	111	C1	121	D1	131
A2	102	B2	112	C2	122	D2	132
A3	103	B3	113	C3	123		
A4	104	B4	114	C4	124		
A5	105	B5	115	C5	125		
A6	106	B6	116	C6	126		
A7	107	B7	117	C7	127		
A8	108	B8	118	C8	128		
A9	109	B9	119	C9	129		

4) Discrete I/O Station Selection (see pages 23-31).



When Ordering:

AKC Manifold Assembly Kit with G2-2 Fieldbus Electronics 2005, 2012 & 2035 Series and ISO 15407-2 Series

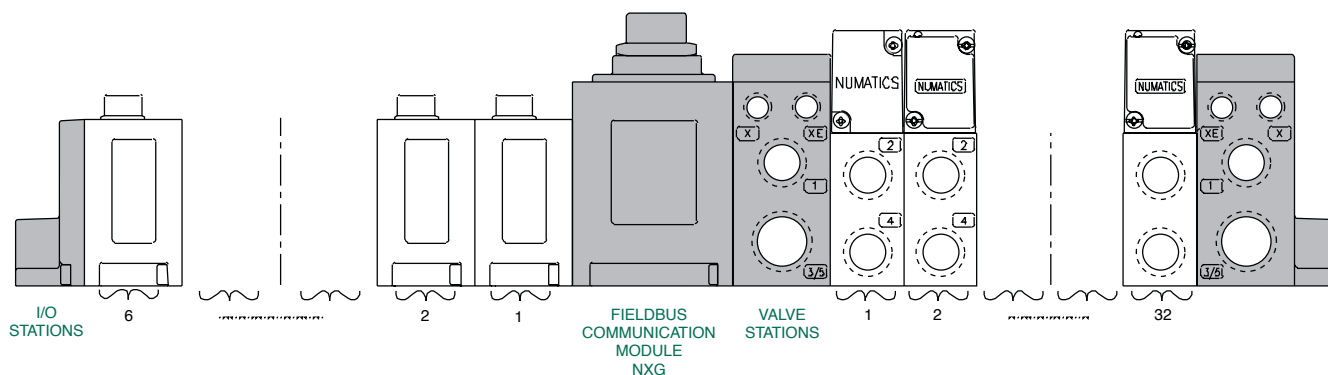

- Shaded components described by Assembly Kit (AK) model number designation (see #1, pg. 27), with the exception of the communication module and number of I/O stations that are described by Electronic Interface (NXG) model number designation. (see #3, pg. 28)
- Each valve manifold station is listed in sequential order from left to right when facing the port side of the manifold as indicated.
- Each discrete I/O station is listed in sequential order from RIGHT to LEFT starting from the communication module as indicated.

NOTE:

1. Total of 32 solenoid outputs available. Either 32 single solenoid valves or 16 double solenoid valves or any combination of singles or doubles, not to exceed 32 solenoid outputs.
2. When ordering a manifold assembly that exceeds 16 solenoids, the model number of the valve station containing the 17th solenoid MUST use a selection for the 7th and 8th digits from the model selection table for the valve type.
3. For manifold assemblies that exceed 16 solenoids, the assembly MUST be configured so an even number of solenoids are utilized prior to the station using the ribbon cable feature. The 16th & 17th solenoid cannot be on the same valve.

Example Order: (2005)

	AKCEP00003NSTD
valve station 1	051BB4Z2MN00061
valve station 2	051BB4Z2MN00061
valve station 3	051BB4Z2MN00061
valve station 4	051BB4Z2MN00061
valve station 5	051BB4Z2MN00061
valve station 6	051BB4Z2MN00061
valve station 7	051BB4Z2MN00061
valve station 8	051BB4Z2MN00061
valve station 9	051BB4R2MN00061
valve station 10	051BB4Z2MN00061
valve station 11	051BB4Z2MN00061
valve station 12	051BB4Z2MN00061
valve station 13	051BB4Z2MN00061
valve station 14	051BB4Z2MN00061
valve station 15	051BB4Z2MN00061
valve station 16	051BB4Z2MN00061
	NXGDN6438DFE02
I/O station 1	239-1317
I/O station 2	239-1317
I/O station 3	239-1319
I/O station 4	239-1467
I/O station 5	239-1480
I/O station 6	239-1460
	ASSEMBLED



When Ordering:

AKE

ISO 5599/2 and 2002 Series Manifold Assembly Kit with G2-2 Fieldbus Electronics (ISO 5599/2 Shown)

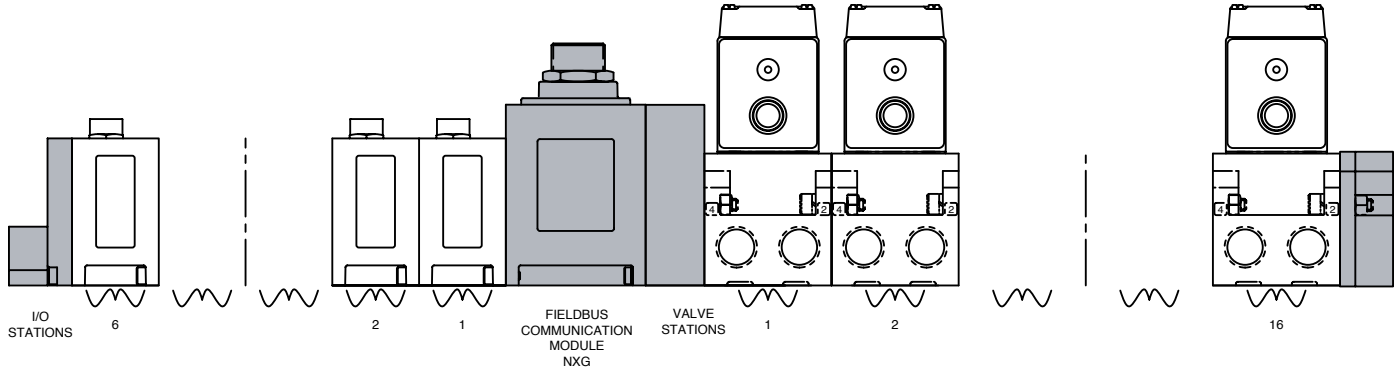

- Shaded components described by assembly Kit (AK) model number designation (*see #1, pg. 27*), with the exception of the communication module and number of I/O stations that are described by Electronic Interface (NXG) model number designation. (*see #3, pg. 28*)
- Each valve manifold station is listed in sequential order from left to right when facing the port side of the manifold as indicated.
- Each discrete I/O station is listed in sequential order from RIGHT to LEFT starting from the communication module as indicated.

NOTE:

1. Total of 32 solenoid outputs available. Either 32 single solenoid valves or 16 double solenoid valves or any combination of singles or doubles, not to exceed 32 solenoid outputs.
2. When ordering a manifold assembly that exceeds 16 solenoids, the model number of the valve station containing the 17th solenoid MUST use a selection for the 7th and 8th digits from model selection table for the valve type.
3. For manifold assemblies that exceed 16 solenoids, the assembly MUST be configured so an even number of solenoids are utilized prior to the station using the ribbon cable feature. The 16th & 17th solenoid cannot be on the same valve.

Example Order: (ISO 5599/2)

	AKEQP00003NSTD
valve station 1	I13BB4Z2MN00061
valve station 2	I13BB4Z2MN00061
valve station 3	I13BB4Z2MN00061
valve station 4	I13BB4Z2MN00061
valve station 5	I13BB4Z2MN00061
valve station 6	I13BB4Z2MN00061
valve station 7	I13BB4Z2MN00061
valve station 8	I13BB4Z2MN00061
valve station 9	I13BB4R2MN00061
valve station 10	I13BB4Z2MN00061
valve station 11	I13BB4Z2MN00061
valve station 12	I13BB4Z2MN00061
valve station 13	I13BB4Z2MN00061
valve station 14	I13BB4Z2MN00061
valve station 15	I13BB4Z2MN00061
valve station 16	I13BB4Z2MN00061
	NXGDN6438DFE02
I/O station 1	239-1317
I/O station 2	239-1317
I/O station 3	239-1319
I/O station 4	239-1869
I/O station 5	239-1870
I/O station 6	239-1460
	ASSEMBLED



When Ordering:

AKV Manifold Assembly Kit with G2-2 Fieldbus Electronics Mark 8, 15, 55 & 2009 Series

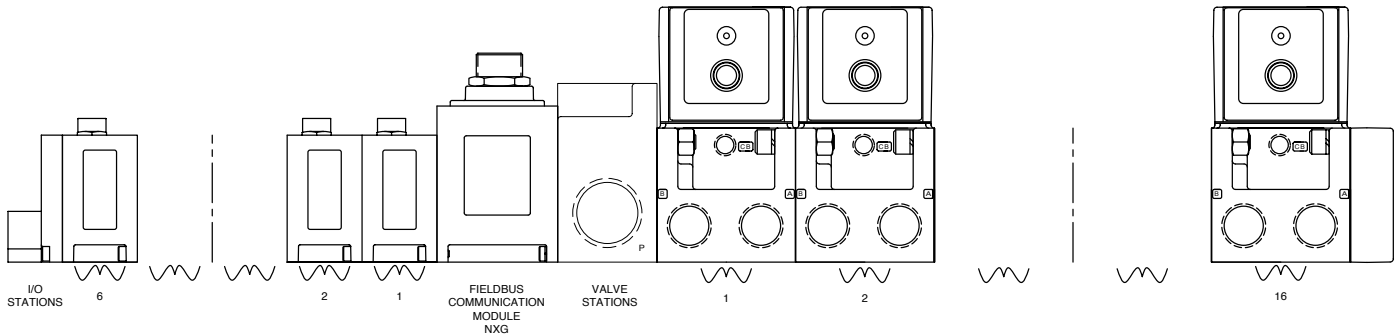

Mark 55 Shown

- Shaded components described by Assembly Kit (AK) model number designation (see #1, pg. 27), with the exception of the communication module and number of I/O stations that are described by Electronic Interface (NXG) model number designation. (see #3, pg. 28)
- Each valve manifold station is listed in sequential order from left to right when facing the port side of the manifold as indicated.
- Each discrete I/O station is listed in sequential order from RIGHT to LEFT starting from the communication module as indicated.

Example Order: (Mark 15)

	AKVJF0004NA05
valve station 1	153SS415M019M61
valve station 2	153SA415M019M61
valve station 3	152SA400M000061
valve station 4	153RS115J019M00
valve station 5	153SS425M019M61
valve station 6	153SA425M019M61
valve station 7	153SS515M019M61
	NXGDN3232DFG15
I/O station 1	239-1994
I/O station 2	239-1317
I/O station 3	239-1871
	ASSEMBLED

NOTE:

1. Total of 32 solenoid outputs available. Either 32 single solenoid valves or 16 double solenoid valves or any combination of singles or doubles, not to exceed 32 solenoid outputs.
2. All valves must have a terminal block in the mounting (19M Option).
3. Valves will be wired based on the number of solenoids on the valve (1 output for a single solenoid valve and 2 for double). If all stations are to be wired for double solenoid valves, option code "A05" must be used in the "AK" number.
4. All blank stations will be wired for double solenoid valves.
5. The NX number must use the "G15" option code for combination of.



Fieldbus Communication Module and Manual Configuration Module Assemblies

Communication Module Kit

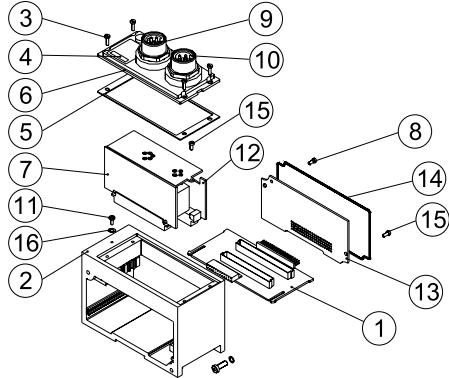

COMMUNICATION MODULE KIT	PART NO.	
	AKC, AKE	AKV
DeviceNet with Mini Comm. Connector (Standard)	239-1514	239-1461
DeviceNet with 12mm Comm. Connector	239-1827	239-1837
Allen-Bradley 1771 RIO with Mini Comm. Connector (Standard)	239-1516	239-1462
Allen-Bradley 1771 RIO with 12mm Comm. Connector	239-1520	239-1838
Profibus-DP (1.5 MBps) with 12mm Comm. Connector	239-1518	239-1463
Profibus-DP (12 MBps) with Reverse Key 12mm Comm. Connection	239-1519	239-1620
Interbus-S	239-2117	239-2118
ControlNet	239-1841	239-1842
DeviceLogix	239-2087	Consult Factory
EtherNet/IP w/ RJ45 Conn.	240-162	Consult Factory
EtherNet/IP w/ M12 Conn.	240-161	Consult Factory
FIPIO	239-2310	Consult Factory
DeviceNet QuickConnect	239-2389	Consult Factory
DeviceNet QuickConnect with Cenelec connector	239-2515	Consult Factory
DeviceNet with Cenelec connector	239-2498	Consult Factory
Foundation Fieldbus (H1 FF)	240-217	Consult Factory
Foundation Fieldbus w/ Logic Transducer	240-243	Consult Factory

AS-I standard addressing mode assemblies

VALVE COIL OUTPUTS	DISCRETE INPUTS	PART NUMBER
4	0	239-2055
4	4	239-2058
8	0	239-2056
8	4	239-2059
8	8	239-2060
12	0	239-2180
12	4	239-2181
12	8	239-2231
12	12	239-2232
16	0	239-2057
16	4	239-2177
16	8	239-2178
16	12	239-2179
16	16	239-2162

DET. NO.	NO. REQ'D	PART NAME	PART NO.
1	1	Backplane Board Ass'y (AKC, AKE)	256-666
	1	Backplane with Drivers (FF & FL only)	256-1036
2	1	Housing (not sold separately)	
3	4	Screw	127-852
4	1	Cover Lens	122-1075
5	1	Gasket	113-533
6	1	Cover	105-416
		Comm. Board Ass'y - DeviceNet w/ Cenelec	256-946
		Comm. Board Ass'y - DeviceNet QuickConnect	256-932
		Comm. Board Ass'y - DeviceNet QuickConnect w/ Cenelec	256-949
		Comm. Board Ass'y - DeviceNet	256-673
		Comm. Board Ass'y - AB1771-RIO	256-678
7	1	Comm. Board Ass'y - Profibus-DP 1.5 & 12MBps	256-710
		Comm. Board Ass'y - DeviceLogix	256-849
		Comm. Board Ass'y - ControlNet	256-789
		Comm. Board Ass'y - EtherNet/IP w/ RJ45 Conn.	240-166
		Comm. Board Ass'y - EtherNet/IP w/ M12 Conn.	240-165
		Comm. Board Ass'y - Foundation Fieldbus (H1 FF)	256-1035
		Comm. Board Ass'y - (FL) w/ Logic Transducer	256-1043
8*	1	Screw	127-794
		5 Pin "Mini" Conn. - DeviceNet & AB 1771-RIO	140-810
		5 Pin Conn. - Profibus DP 1.5MBps	140-847
9	1	5 Pin 12mm male - DeviceNet & AB 1771 RIO	140-847
		5 Pin 12mm reverse key - Profibus DP 12MBPS	140-848
10	1	4 Pin Conn.	140-809
11	1	Ground Screw	127-176
12	1	Driver Board Ass'y	256-680
13*	1	Converter Board Ass'y	256-671
14	2	Gasket	113-531
15*	2	Ground Screw	127-318
16	1	Washer	128-162
	1	Valve & Output Fuse (10A)	140-934
	1	Node Input Fuse (4A)	140-933

*Not used with AKV kits.

AS-I extended addressing module assemblies

VALVE COIL OUTPUTS	DISCRETE INPUTS	PART NUMBER
3	0	239-2171
3	4	239-2172
6	0	239-2166
6	4	239-2165
6	8	239-2164
9	0	239-2176
9	4	239-2175
9	8	239-2174
9	12	239-2173
12	0	239-2169
12	4	239-2168
12	8	239-2167
12	12	239-2170
12	16	239-2163

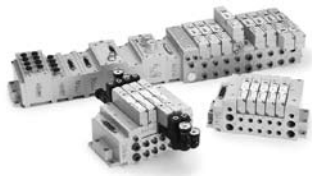

Manual Configuration Module (MCM) Kit
(For All Protocols)

239-1384

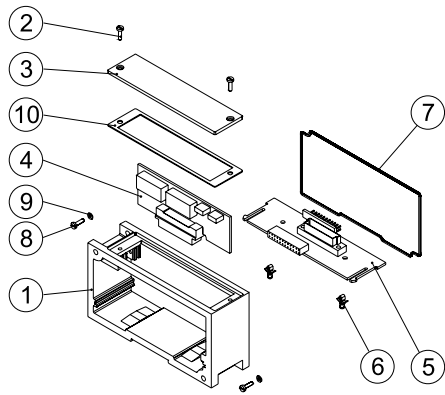

DET. NO.	NO. REQ'D	PART NAME	PART NO.
1	1	Housing (not sold separately)	
2	2	Screw	127-852
3	1	Cover	105-418
4	1	Switch Board Assembly	256-684
5	1	Switch Backplane	256-672
6	2	Support Pin	140-828
7	2	Gasket	113-531
8	2	Screw	127-697
9	2	Lockwasher	128-188
10	1	Gasket	113-532

- The MCM is an optional module that is used to manually configure communication parameters as well as allowing user access to self-test diagnostic functionality.

12mm I/O Block Assemblies

Digital Input/Output with SCP and Logical Diagnostics Module Kit

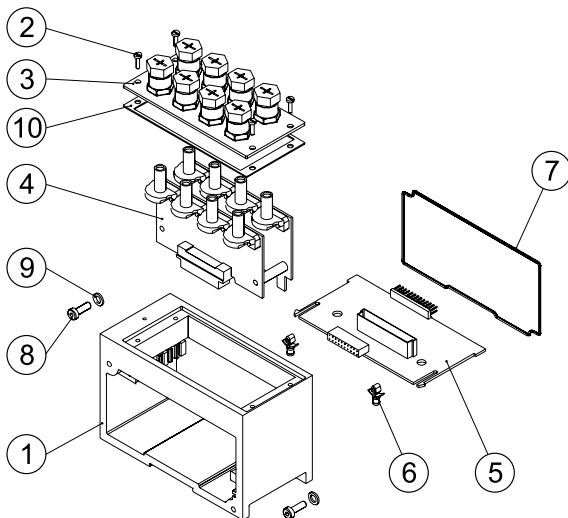

DET. NO.	NO. REQ'D	PART NAME	PART NO.
1	1	Housing (not sold separately)	
2	2	Screw	127-852
3	1	I/O Cover Assembly 8 I/O Points	205-381
	1	I/O Cover Assembly 16 I/O Points	205-382
4	1	I/O Board Ass'y	See Chart Below
5	1	I/O Backplane	256-665
6	2	Support Pin	140-828
7	1	Gasket	113-531
8	2	Screw	127-697
9	2	Lockwasher	128-188
10	1	Gasket	113-533
	1	I/O Connector Dust Cover	230-647

- These short circuit protected (SCP) I/O modules offer enhanced diagnostics. Sensor and/or cable short circuit conditions are detected and source power to sensor device is disabled while a visual and/or logical diagnostic bit is created back to the PLC/IPC.

DESCRIPTION	PART NO.
16 Input PNP w/ visual and logical diagnostics	239-2564
Replacement I/O Board for above	240-129
8 Input/ 8 Output PNP w/ visual and logical diagnostics	239-2522
Replacement I/O Board for above	240-127



12mm I/O Block Assemblies

Digital Input/Output Module Kit 4/8

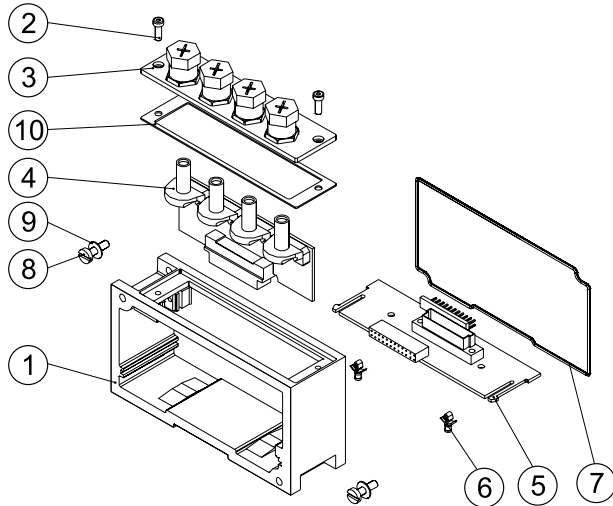

DET. NO.	NO. REQ'D	PART NAME	PART NO.
1	1	Housing (not sold separately)	
2	2	Screw	127-852
3	1	I/O Cover Assembly 4 I/O Points	205-377
	1	I/O Cover Assembly 8 I/O Points	205-378
4	1	I/O Board Ass'y	See Chart Below
5	1	I/O Backplane	256-672
6	2	Support Pin	140-828
7	1	Gasket	113-531
8	2	Screw	127-697
9	2	Lockwasher	128-188
10	1	Gasket	113-532
	1	I/O Connector Dust Cover	230-647

	4 INPUTS	4 OUTPUTS	8 INPUTS	8 OUTPUTS
Sinking (NPN)	239-1304	N/A	239-1308	N/A
Replacement I/O Board for above	240-100	N/A	240-104	N/A
Sourcing (PNP)	239-1305	239-1307	239-1309	239-1311
Replacement I/O Board for above	240-101	240-103	240-105	240-107

Digital Input/Output with SCP Module Kit 8/16

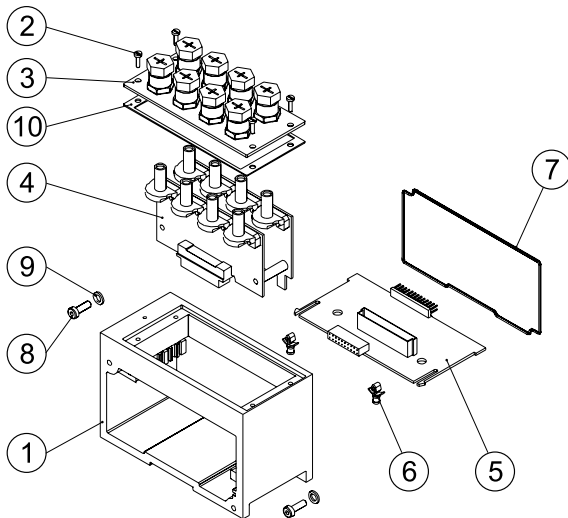

DET. NO.	NO. REQ'D	PART NAME	PART NO.
1	1	Housing (not sold separately)	
2	2	Screw	127-852
3	1	I/O Cover Assembly 8 I/O Points	205-381
	1	I/O Cover Assembly 16 I/O Points	205-382
4	1	I/O Board Ass'y	See Chart Below
5	1	I/O Backplane	256-665
6	2	Support Pin	140-828
7	1	Gasket	113-531
8	2	Screw	127-697
9	2	Lockwasher	128-188
10	1	Gasket	113-533
	1	I/O Connector Dust Cover	230-647

	8 INPUTS	8 OUTPUTS	16 INPUTS	16 OUTPUTS
Sinking (NPN)	240-130	N/A	240-132	N/A
Replacement I/O Board for above	240-134	N/A	240-136	N/A
Sourcing (PNP)	240-131	239-1315	239-2500	239-1319
Replacement I/O Board for above	240-135	240-112	240-125	240-116

- These short circuit protected (SCP) I/O modules offer enhanced diagnostics. Sensor and/or cable short circuit conditions are detected and source power to sensor device is disabled while a visual diagnostic created.

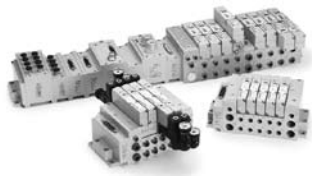

I/O Block Assemblies

Digital Terminal Strip Input/Output Module

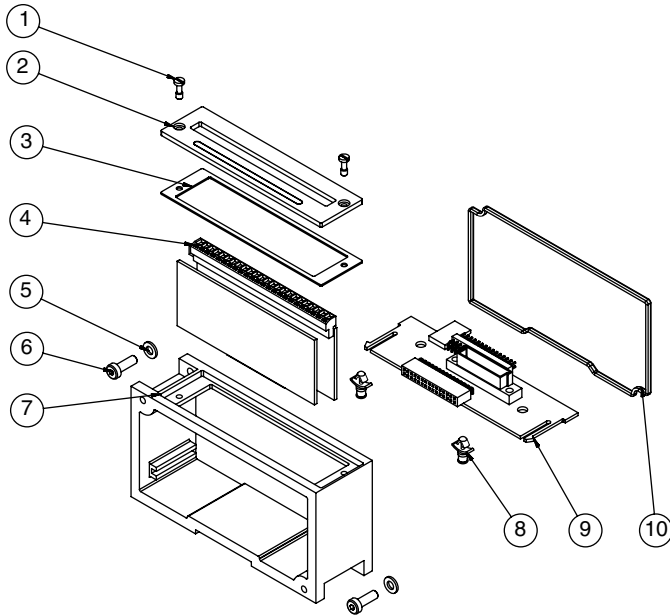

DET. NO.	NO. REQ'D	PART NAME	PART NO.
1	2	Screw	127-852
2	1	Cover	105-461
3	1	Gasket	113-532
4	1	16 I/O Terminal Strip Board	256-898
5	2	Lockwasher	128-188
6	2	Screw	127-697
7	1	Housing	125-1135
8	2	Support Pin	140-828
9	1	I/O Backplane Board	256-672
10	1	Gasket	113-531

	16 INPUTS	16 OUTPUTS
Sinking (NPN)	239-2304	N/A
Replacement I/O Board for above	256-894	N/A
Sourcing (PNP)	239-2311	239-2518
Replacement I/O Board for above	256-898	256-652

Analog 12mm Input/Output Module Kit

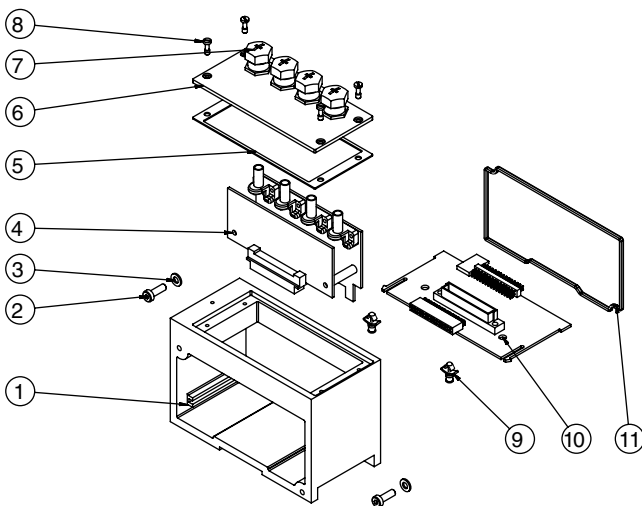

DET. NO.	NO. REQ'D	PART NAME	PART NO.
1	1	Housing	125-802
2	2	Screw	127-697
3	2	Lockwasher	128-188
4	1	I/O Board Assembly	256-863
5	1	Gasket	113-533
6	1	I/O Cover	105-455
7	1	I/O Connector Dust Cover	230-647
8	1	Screw	127-852
9	2	Support Pin	140-828
10	1	I/O Backplane Board Assembly	256-665
11	1	Gasket	113-531

	2 IN / 2 OUT	3 IN / 1 OUT
0-10V	239-2153	239-2154
Replacement I/O Board for above	240-118	240-119
0-5V	239-2155	239-2156
Replacement I/O Board for above	240-120	240-121
4-20 mA	239-2157	239-2158
Replacement I/O Board for above	240-122	240-123



25 Pin Sub-D Connector Digital Input Module (16 inputs)

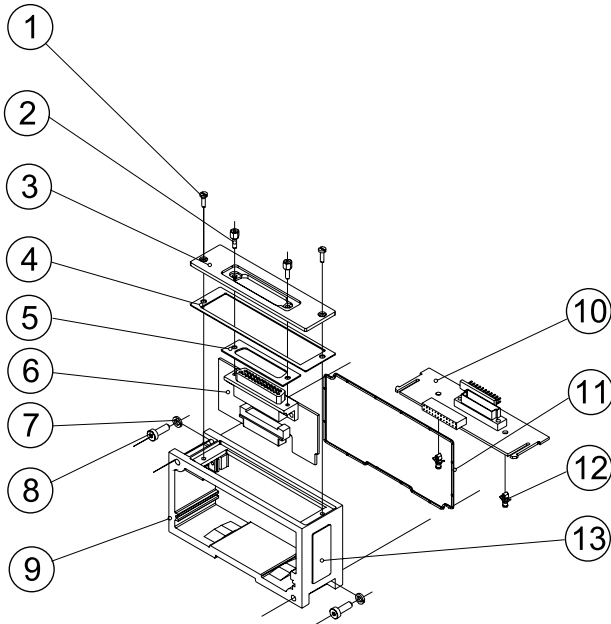

DET. NO.	NO. REQ'D	PART NAME	PART NO.
1	2	Screw	127-852
2	4	Hex Screw	127-825
3	1	Cover	105-427
4	1	Gasket	113-532
5	2	Gasket	113-507
6	1	Input Module Board Ass'y (Sinking NPN)	256-797
6	1	Input Module Board Ass'y (Sourcing PNP)	256-799
7	2	Lockwasher	128-188
8	2	Screw	127-697
9	1	Housing (not sold separately)	
10	1	I/O Backplane Board Ass'y	256-672
11	1	Gasket	113-531
12	2	Support Pin	140-828
13	2	Nameplate	122-1057

25 PIN SUB-D INPUT KITS	PART NO.
16 Point Sinking (NPN)	239-1869
16 Point Sourcing (PNP)	239-1871

Dual 15 Pin Sub-D Connector Digital Input Module (16 inputs)

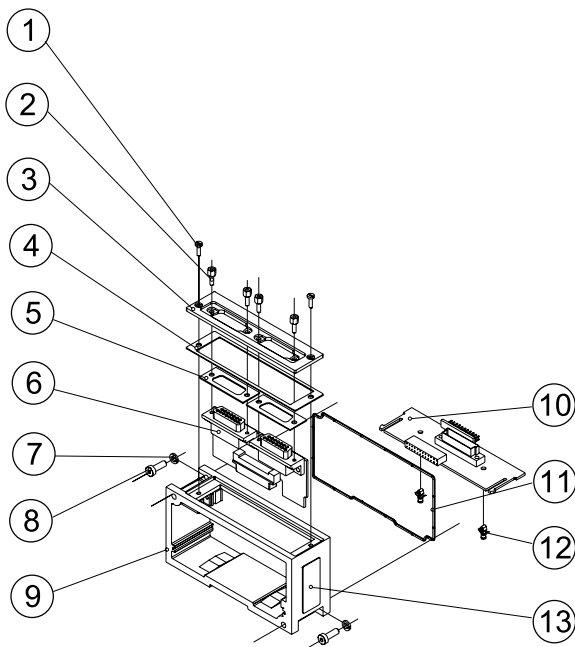

DET. NO.	NO. REQ'D	PART NAME	PART NO.
1	2	Screw	127-852
2	4	Hex Screw	127-825
3	1	Cover	105-426
4	1	Gasket	113-532
5	2	Gasket	113-566
6	1	Input Module Board Ass'y (Sinking NPN)	256-796
6	1	Input Module Board Ass'y (Sourcing PNP)	256-798
7	2	Lockwasher	128-188
8	2	Screw	127-697
9	1	Housing (not sold separately)	
10	1	I/O Backplane Board Ass'y	256-672
11	1	Gasket	113-531
12	2	Support Pin	140-828
13	2	Nameplate	122-1057

DUAL 15 PIN SUB-D INPUT KITS	PART NO.
16 Point Sinking (NPN)	239-1868
16 Point Sourcing (PNP)	239-1870

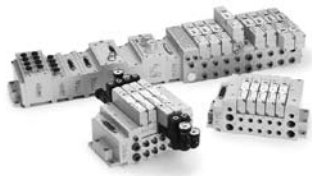

**19 Pin M23 Circular Connector Digital I/O Module
(8 Inputs and 8 Outputs)**

239-2196

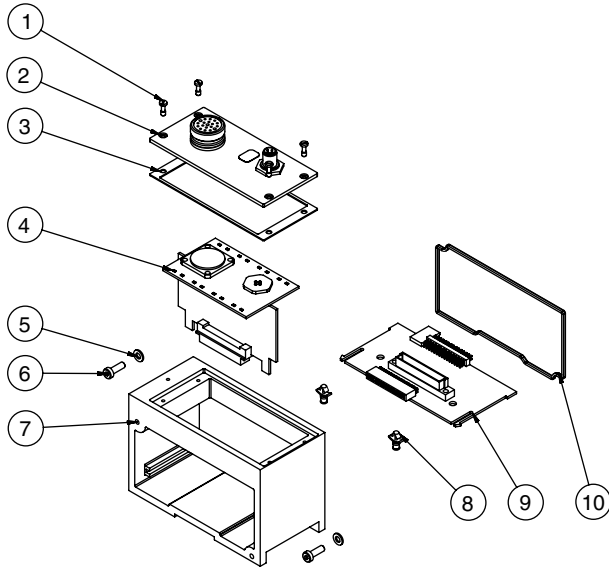

DET. NO.	NO. REQ'D	PART NAME	PART NO.
1	4	Screw	127-852
2	1	Cover	105-458
3	1	Gasket	113-533
4	1	18 Pin 8 I/O Board Assembly	256-880
5	2	Lockwasher	128-188
6	2	Screw	127-697
7	1	Housing	125-802
8	2	Support Pin	140-828
9	1	I/O Backplane Board Assembly	256-665
10	1	Gasket	113-531

**19 Pin M23 Circular Connector Digital Input Module
(16 Inputs)**

239-2382

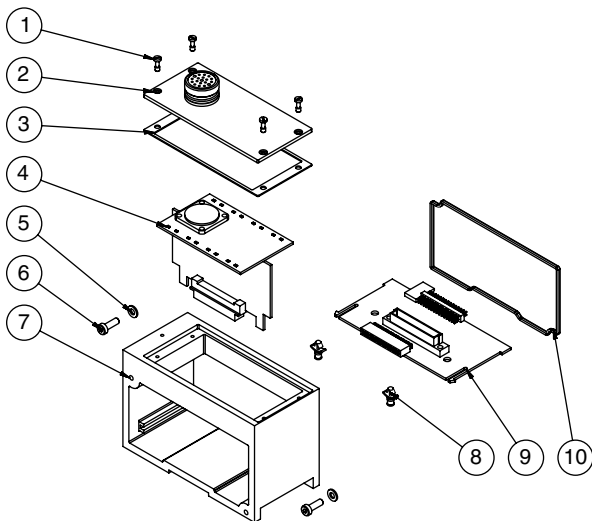

DET. NO.	NO. REQ'D	PART NAME	PART NO.
1	4	Screw	127-852
2	1	Cover	105-465
3	1	Gasket	113-533
4	1	19 Pin 16 Input Board Assembly	256-930
5	2	Lockwasher	128-188
6	2	Screw	127-697
7	1	Housing	125-802
8	2	Support Pin	140-828
9	1	I/O Backplane Board Assembly	256-665
10	1	Gasket	113-531



25 Pin Sub-D Connector Digital Output Module w/Aux. Power Connector (22 Outputs)

239-1460

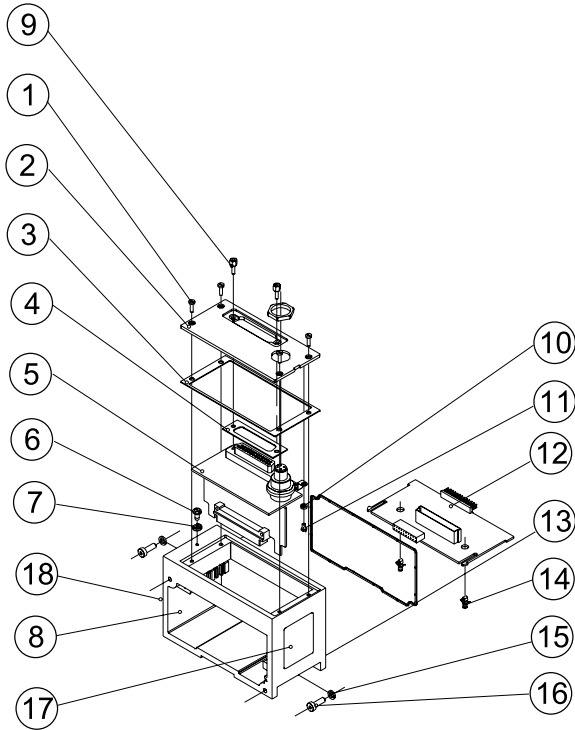

DET. NO.	NO. REQ'D	PART NAME	PART NO.
1	4	Screw	127-852
2	1	Cover	105-425
3	1	Gasket	113-533
4	1	Gasket	113-507
5	1	Output Board Ass'y	256-722
6	1	Screw	127-176
7	1	Washer	128-162
8	1	Housing	125-802
9	2	Jack Screw	127-825
10	1	Washer	128-350
11	1	Screw	127-172
12	1	I/O Backplane Board Ass'y	256-665
13	1	Gasket	113-531
14	2	Support Pin	140-828
15	2	Lockwasher	128-188
16	1	Screw	127-697
17	1	Nameplate	122-1058
18	1	Nameplate	122-1057
	1	Replacement Fuse (4A)	140-933

Dual 25 Pin Sub-D Connector Digital Output Module with Aux. Power Connector (32 Outputs)

239-1994

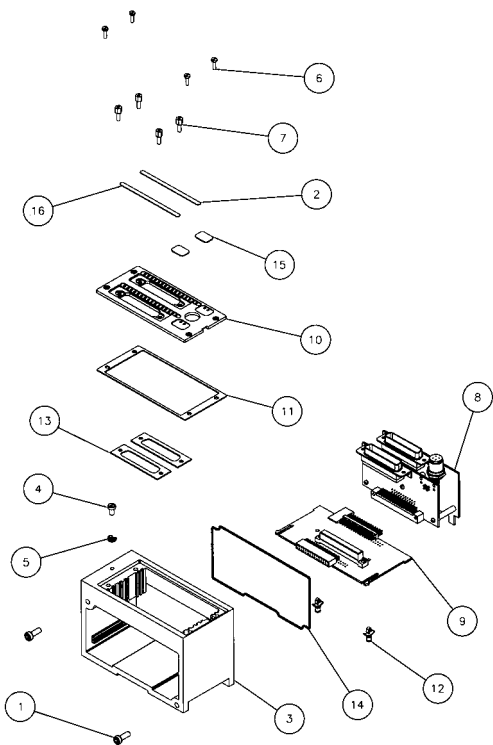

DET. NO.	NO. REQ'D	PART NAME	PART NO.
1	2	Screw	127-697
2	1	Cover Lens	122-1153
3	1	Housing	125-802
4	1	Ground Screw	127-176
5	1	Cup Washer	128-162
6	4	Screw	127-852
7	4	Jack Screw	127-825
8	1	Dual Sub-D Output Board	256-825
9	1	Backplane Board Assembly	256-665
10	1	Cover	105-448
11	1	Gasket	113-533
12	2	Support Pin	140-828
13	2	Gasket	113-507
14	1	Gasket	113-531
15	2	Lens	122-1180
16	1	Cover Lens	122-1156
	2	Replacement Fuse (4A)	140-933



Valve Side Output Modules

Dual 25 Pin Sub-D Output Module

239-1867

- Used without valves only
- Located between communication module and right mounting cover
- Provides 32 output capability 16 outputs per connector.

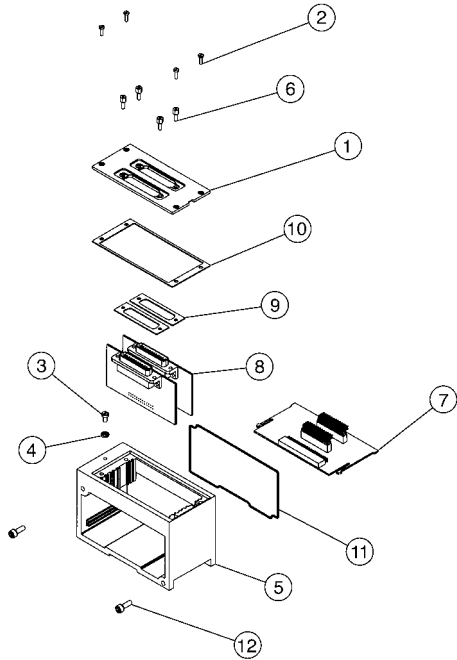

DET. NO.	NO. REQ'D	PART NAME	PART NO.
1	1	Cover, Dual Sub-D	105-445
2	4	Screw	127-852
3	1	Ground Screw	127-176
4	1	Cup Washer	128-162
5	1	Housing	125-802
6	4	Jack Screw	127-825
7	1	Backplane, Dual Sub-D	256-794
8	2	Connector Board	256-795
9	2	Gasket, 25 Pin Sub-D	113-507
10	1	Gasket, Cover	113-533
11	1	Gasket, Housing	113-531
12	2	Screw Assembly	127-396

Single 25 Pin Sub-D Output Module

239-1713

- Used to connect auxiliary valve manifold when main manifold utilizes 16 solenoids output or less.
- Picks up solenoid outputs 17-32.

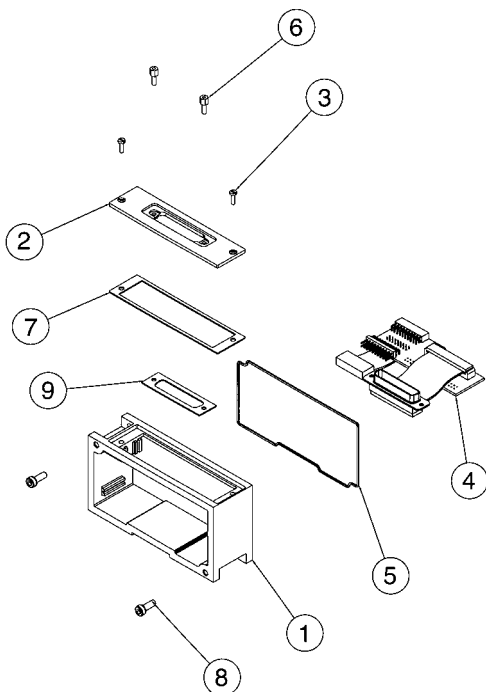

DET. NO.	NO. REQ'D	PART NAME	PART NO.
1	1	Housing	125-801
2	1	Cover	105-427
3	2	Screw	127-852
4	1	P.C. Board Assembly	256-741
5	1	Gasket	113-531
6	2	Jack Screw	127-825
7	1	Gasket	113-532
8	2	Screw	127-697
9	1	Gasket	113-507



Valve Side Output Modules

19 Pin M23 Circular Output Module

239-2379

- Used to connect auxiliary valve manifold when main manifold utilizes 16 solenoids output or less.
- Picks up solenoid outputs 17-32.

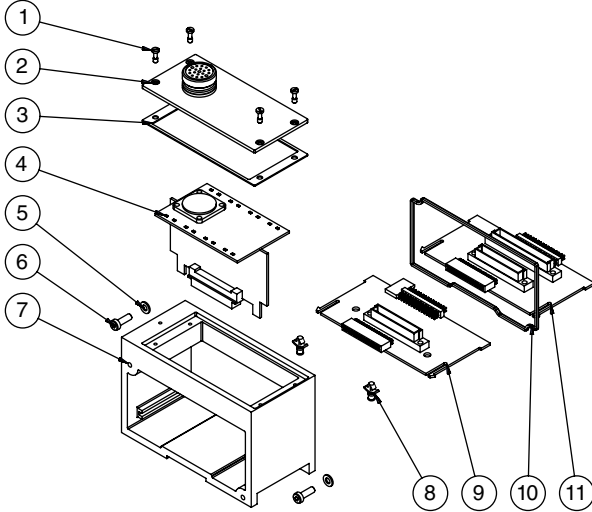

DET. NO.	NO. REQ'D	PART NAME	PART NO.
1	4	Screw	127-852A
2	1	Cover	105-465B
3	1	Gasket	113-533B
4	1	19 Pin 16 Output Board Assembly	256-929B
5	2	Lockwasher	128-188A
6	2	Screw	127-697A
7	1	Housing	125-802B
8	2	Support Pin	140-828A
9	1	Backplane Board Assembly	256-927B
10	1	Gasket	113-531B
11	1	Backplane Board Assembly	256-952B

Dual 15 Pin Sub-D Output Module

239-2041

- Use with cable on *page 42* to connect with standard 25 Pin Sub-D Manifold with 8 coils or less.
- 8 outputs per connector.

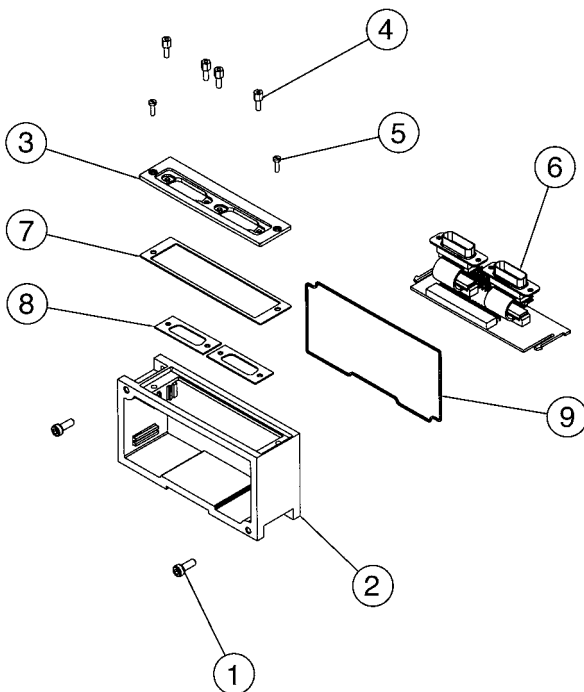

DET. NO.	NO. REQ'D	PART NAME	PART NO.
1	2	Screw	127-697
2	1	Housing	125-801
3	1	Cover	105-426
4	4	Jack Screw	127-825
5	2	Screw	127-852
6	1	Dual 15 Pin Sub-D Board Assembly	256-847
7	1	Gasket	113-532
8	2	Gasket	113-566
9	1	Gasket	113-531

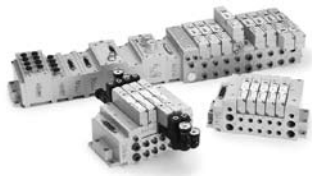

Left Mounting Cover Assembly

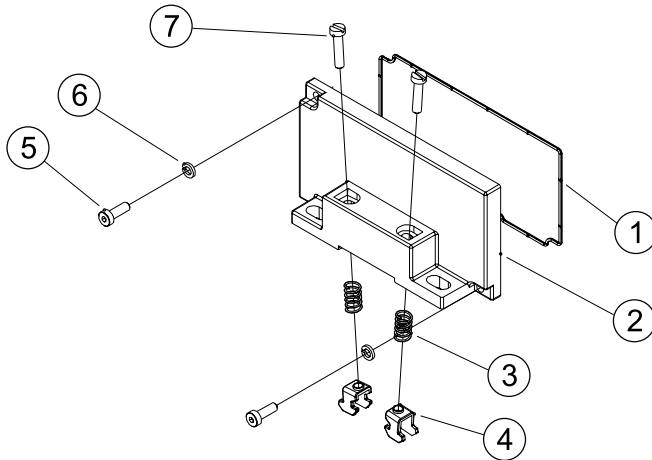

LEFT HAND MOUNTING COVER ASSEMBLY		PART NO.
Without DIN		239-1816
With DIN		239-1815

DET. NO.	NO. REQ'D	PART NAME	PART NO.
1	1	Gasket	113-531
2	1	Mounting Cover	105-403
3	2	Spring (DIN Rail Only)	115-355
4	2	Clamp (DIN Rail Only)	125-720
5	2	Screw	127-697
6	2	Lockwasher	128-188
7	2	Screw (DIN Rail Only)	127-472

Right Mounting Cover Assembly

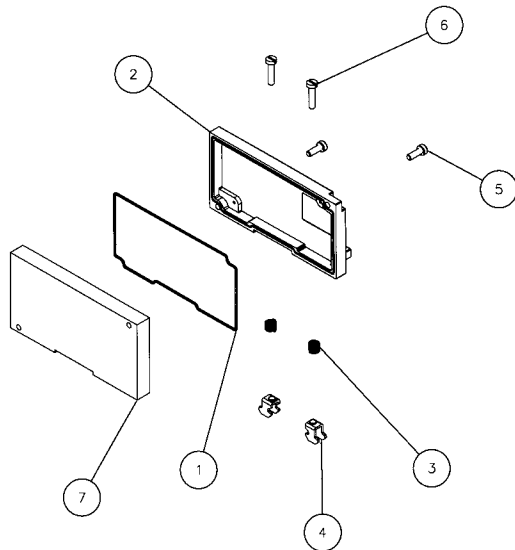

RIGHT HAND MOUNTING COVER ASSEMBLY		PART NO.
Without DIN		239-1873
With DIN		239-1872

DET. NO.	NO. REQ'D	PART NAME	PART NO.
1	1	Gasket	113-531
2	1	Mounting Cover	105-403
3	2	Spring (DIN Rail Only)	115-355
4	2	Clamp (DIN Rail Only)	125-720
5	2	Screw	127-697
6	2	Screw (DIN Rail Only)	127-472
7	1	Adaptor Plate	119-734

**Adapter Kit
2002 Series to G2-2 Electronics**

239-2094

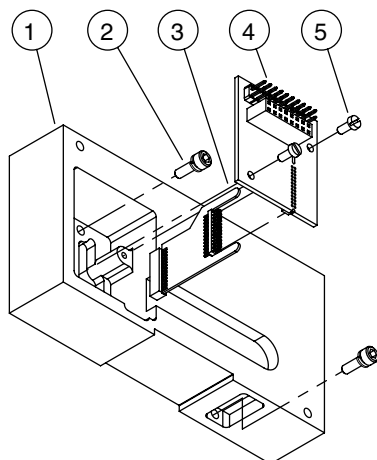

DET. NO.	NO. REQ'D	PART NAME	PART NO.
1	1	Adapter Plate	119-743
2	2	Screw	127-794
3	1	PC Board Assembly	256-852
4	1	PC Board Assembly	256-853
5	2	Screw w/ Lockwasher	127-564



Dimensional Drawing G2-2 Fieldbus Communication Assembly

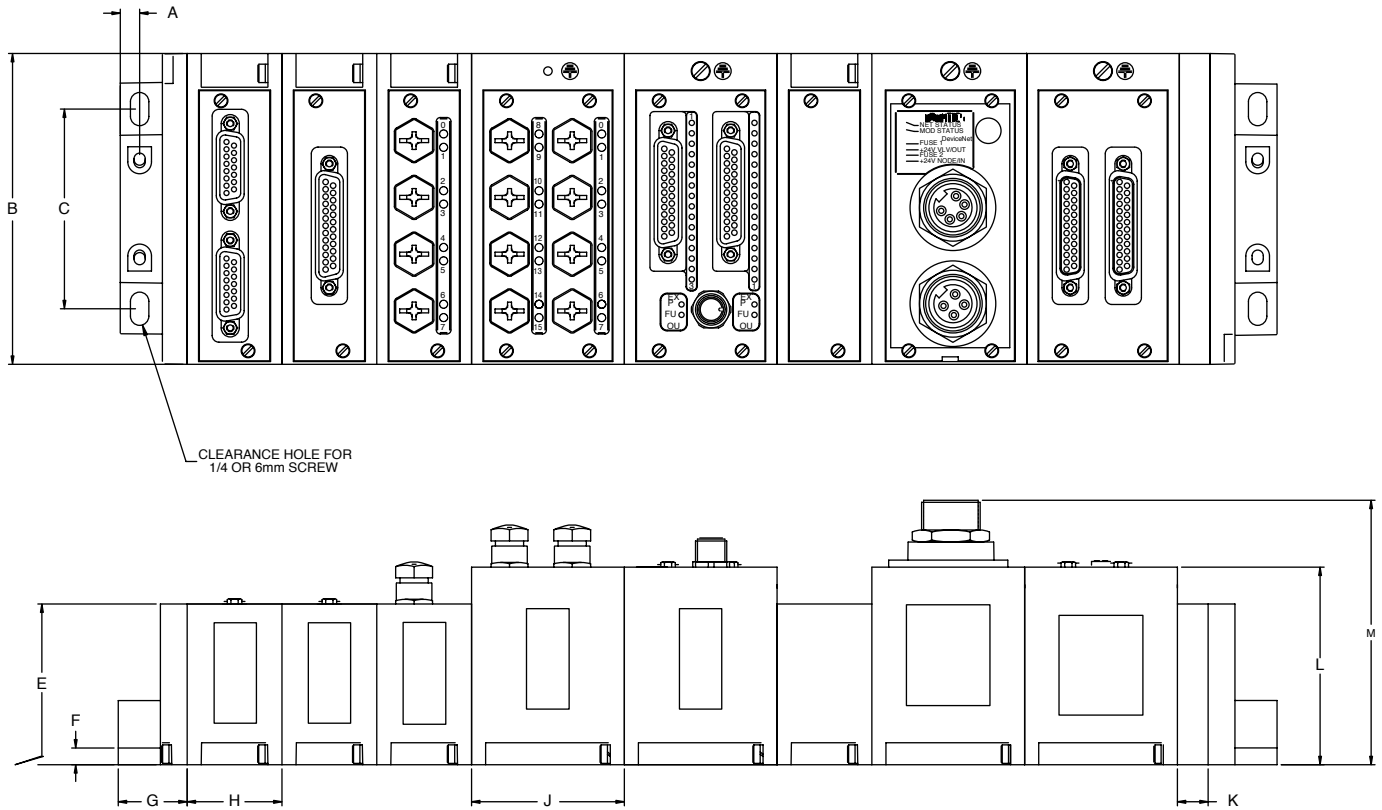

Dimensions

top dimensions = inches
bottom dimensions (in parenthesis) = millimeters

A	B	C	E	F	G	H	J	K	L	M
0.29 (7.4)	4.65 (118.1)	2.98 (75.7)	2.40 (61.0)	1.00 (25.4)	1.00 (25.4)	1.42 (36.1)	2.28 (57.9)	0.46 (11.7)	2.95 (74.9)	3.95 (100.3)



Individual Base Node

Individual Base Node (IBN)

Why use Numatics Fieldbus communication electronics? **Modular Reality**

- Up to 2 discrete output points and 2 valve solenoids and input points per valve assembly
- Enhanced diagnostics include discrete I/O status with short circuit protection
- Software or manual configuration simplifies commissioning
- Plug-together flexibility
- Conformance tested ensures compatibility
- Shorted and open load diagnostics
- NEMA 4/IP65 protected against water splash

Supported Protocols:

- DeviceLogix
- DeviceNet

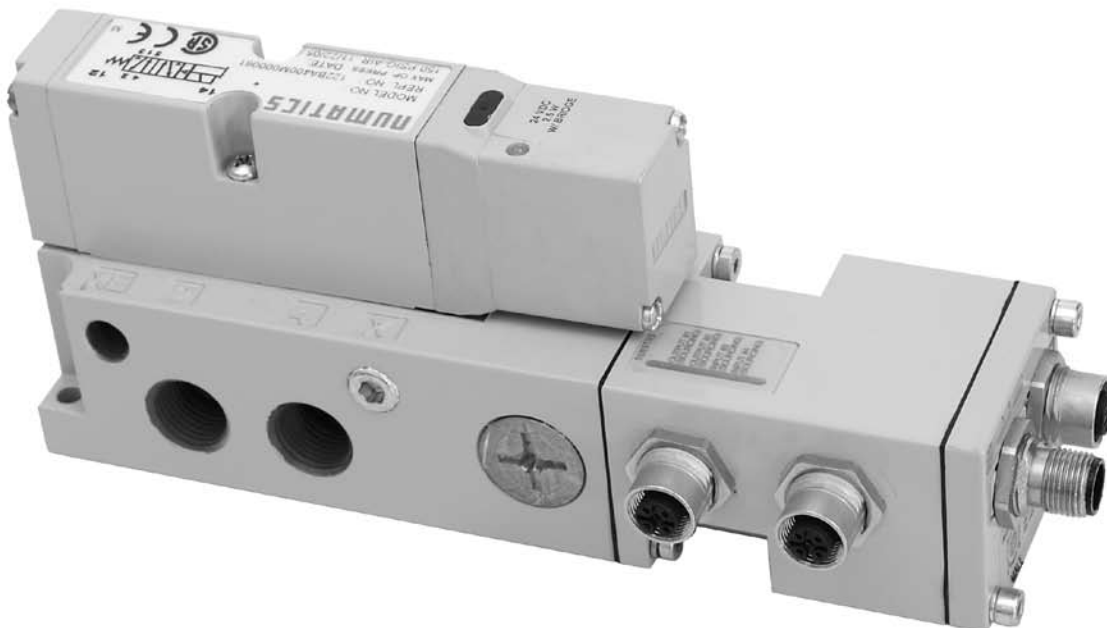



DeviceLogix

DeviceLogix is a Rockwell Automation technology that allows a DeviceNet node to be programmed to execute a sequence independently from the control for the main PLC/IPC. A DeviceLogix enabled DeviceNet node can be used in conjunction with a standard DeviceNet network, providing simple distributed control functionality. Additionally, it can also be used in a standalone application, without a network connection or PLC/IPC, to sequence pneumatic valves and control I/O. Numatics has integrated this licensed technology into its DeviceNet compatible valve manifold series, which combine the functionality of a modular pneumatic valve system with integrated I/O.

Programming of the DeviceLogix enabled node is done using the industry standard DeviceNet commissioning software tool RSNetworkx for DeviceNet for Rockwell Automation. The programming software features an easily understandable graphics environment where the users can simply “drag and drop” logic function blocks (i.e. AND, NAND, OR, NOR, XOR, XNOR, RS LATCHES, COUNTERS and TIMERS) onto a page and interconnect them to develop the required sequence, or ladder logic programming can be used to develop a sequence. The programmed sequence is downloaded to the node via the standard DeviceNet communication connection, thus multiple nodes can be programmed simultaneously on the same network.

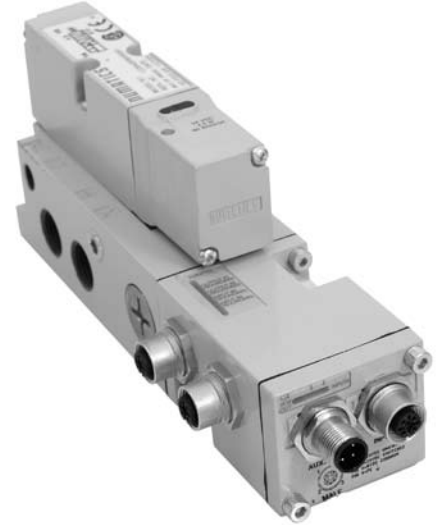

Technical Data

ELECTRICAL DATA		VOLTAGE	CURRENT
Node Power		24 VDC +/- 10%	0.040 amps.
Bus Power		11-25 VDC	0.025 amps.
Valve & Discrete I/O		24 VDC +/- 10%	8 amps. maximum
Aux Power Connector		Single key 4 pin 12mm micro type (male)	
Communication Connector		Single key 5 pin 12mm micro type (male)	
LED's		Module Status, Network status, Auxiliary power status, Logic enabled and I/O status	
OPERATING DATA			
Temperature Range		-10° to +115° F (-23° to +46° C)	
Humidity		95% relative humidity, non condensing	
Moisture		Designed to meet NEMA 4 / IP65 requirements	
CONFIGURATION DATA			
Communication Module		Contains all communication electronics as well as short circuit protected driver circuitry for up to 2 valve solenoids	
Maximum Valve Solenoid Outputs		2	
Maximum Discrete I/O Points		Various Combinations of 2 outputs and 6 inputs	
NETWORK DATA			
Supported Baud Rates		125K, 250K, 500K and Autobaud	
Supported Connection Types		Polled, Cyclic, Change of State (COS) and Combination Message Capability	
Bus Connector		Single key 5 pin 12mm micro type (male)	
Diagnostics		Shorts and open load conditions from valve solenoid coils & outputs are monitored	
Special Features		Supports Auto-Device Replacement (ADR)	

Electronic Data Sheet (EDS) file and technical manuals are available in the download section of the Numatics, Inc. web site at: www.numatics.com/fieldbus



Individual Base Node

DeviceNet

DeviceNet is an open protocol bus communication system by Allen-Bradley based on Controller Area Network (CAN) technology. The governing body for DeviceNet is the Open DeviceNet Vendors Association (ODVA). The ODVA controls the DeviceNet specification and oversees product conformance testing.

More information about DeviceNet and the ODVA can be obtained from www.odva.org

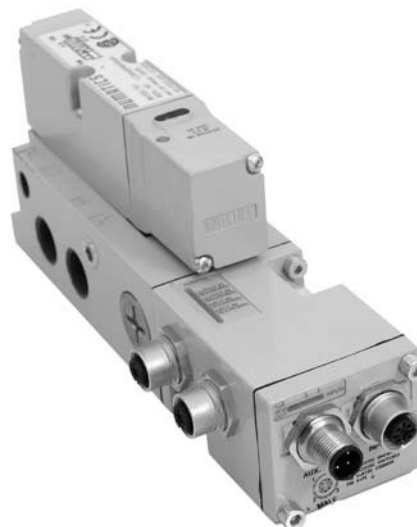

Technical Data

ELECTRICAL DATA		VOLTAGE	CURRENT
Node Power		24 VDC +/- 10%	0.040 amps.
Bus Power		11-25 VDC	0.025 amps.
Valve & Discrete I/O		24 VDC +/- 10%	8 amps. maximum
Aux Power Connector		Single key 4 pin 12mm micro type (male)	
Communication Connector		Single key 5 pin 12mm micro type (male)	
LED's		Module Status, network status, auxiliary power status and I/O status	
OPERATING DATA			
Temperature Range		-10° to +115° F (-23° to +46° C)	
Humidity		95% relative humidity, non condensing	
Moisture		Designed to meet NEMA 4 / IP65 requirements	
CONFIGURATION DATA			
Communication Module		Contains all communication electronics as well as short circuit protected driver circuitry for up to 22 valve solenoids	
Maximum Valve Solenoid Outputs		2	
Maximum Discrete I/O Points		Various Combinations of 2 outputs and 6 inputs	
NETWORK DATA			
Supported Baud Rates		125K, 250K, 500K and Autobaud	
Supported Connection Types		Polled, Cyclic, Change of State (COS) and Combination Message Capability	
Bus Connector		Single key 5 pin 12mm micro type (male)	
Diagnostics		Shorts and open load conditions from valve solenoid coils & outputs are monitored	
Special Features		Supports Auto-Device Replacement (ADR)	

Electronic Data Sheet (EDS) file and technical manuals are available in the download section of the Numatics, Inc. web site at: www.numatics.com/fieldbus



Individual Base Node

How to Order

Valves

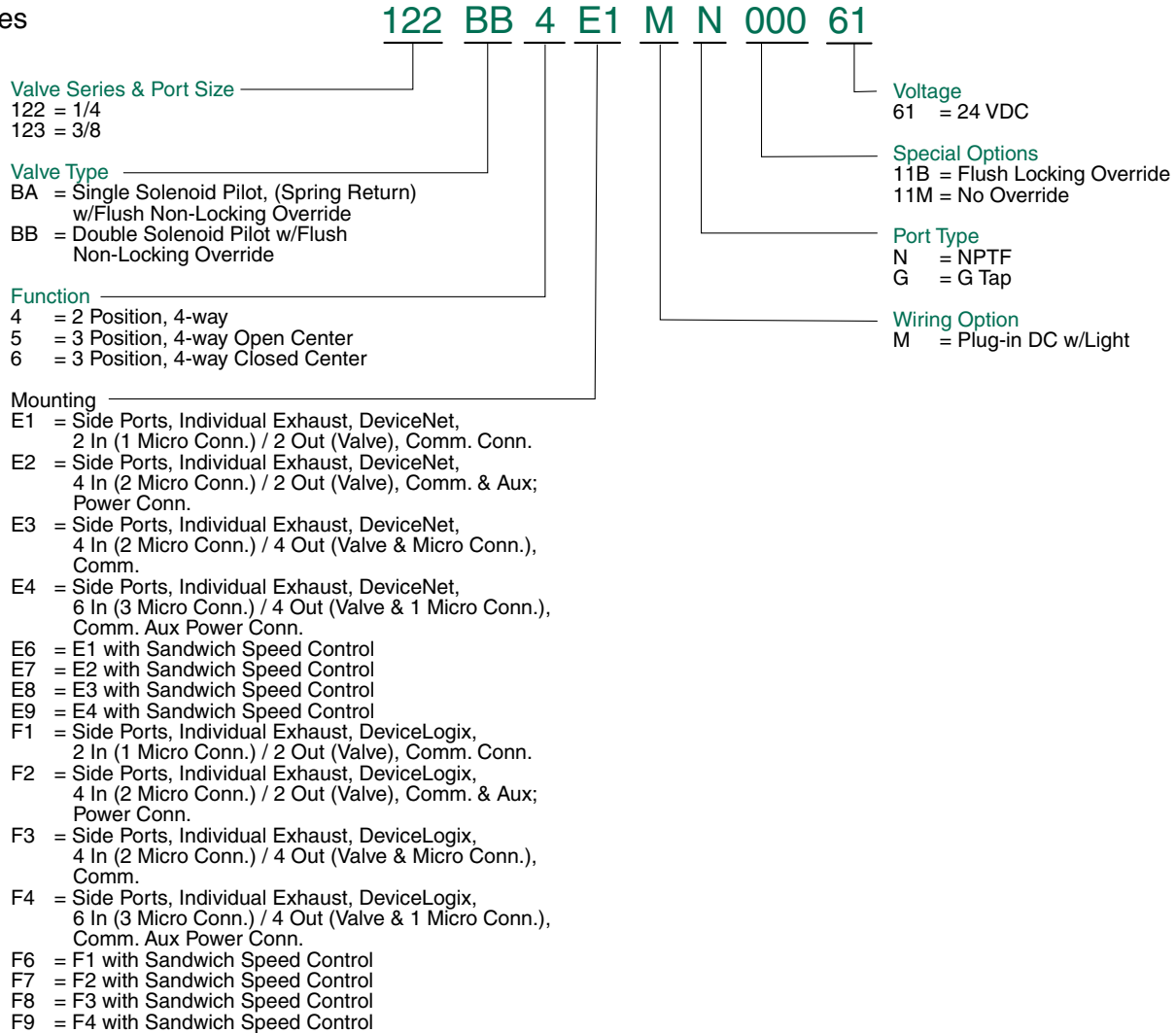



Individual Base Node

Valve on Individual Base Node

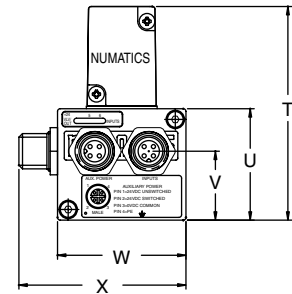
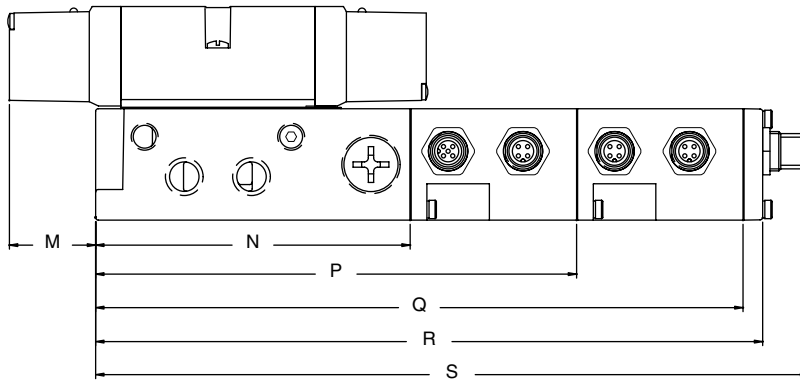
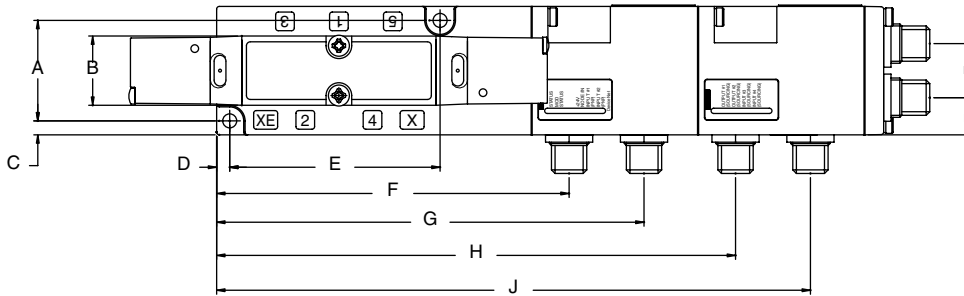

Dimensions

top dimensions = inches
bottom dimensions (in parenthesis) = millimeters

A	B	C	D	E	F	G	H	J	K	L	M	N	P	Q	R
1.51	1.04	0.21	0.20	3.16	5.29	6.42	7.79	8.92	0.81	0.56	1.30	4.72	7.22	9.72	10.02
(38.3)	(26.4)	(5.3)	(5.0)	(80.3)	(134.5)	(163.0)	(198.0)	(226.5)	(20.6)	(14.2)	(32.9)	(120.0)	(183.5)	(247.0)	(254.5)

S	T	U	V	W	X
10.71	3.21	1.67	1.04	1.93	2.51
(272.1)	(81.5)	(42.5)	(26.3)	(49.0)	(63.7)



Individual Base Node

2 Solenoid Outputs/2 Inputs

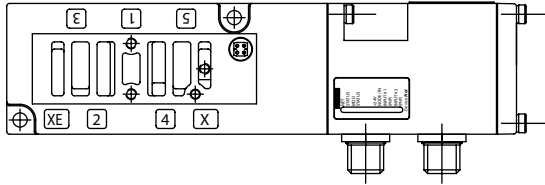

2 Solenoid Outputs/4 Inputs and Auxiliary Power Connector

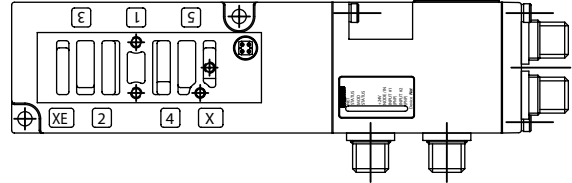

Base Assemblies

Port Size	DeviceLogix (F1)	DeviceNet (E1)
1/4 NPTF	203-1246	203-1230
3/8 NPTF	203-1247	203-1231
1/4 G	203-1248	203-1232
3/8G	203-1249	203-1233

Base Assemblies

Port Size	DeviceLogix (F2)	DeviceNet (E2)
1/4 NPTF	203-1250	203-1234
3/8 NPTF	203-1251	203-1235
1/4 G	203-1252	203-1236
3/8G	203-1253	203-1237

2 Solenoid Outputs/4 Inputs and 2 Outputs

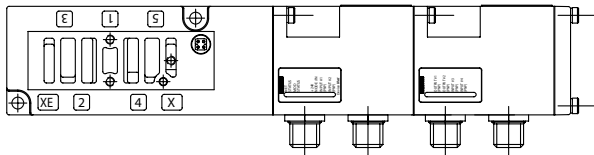

2 Solenoid Outputs/6 Inputs/2 Outputs and Auxiliary Power Connector

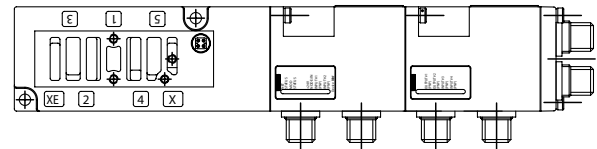

Base Assemblies

Port Size	DeviceLogix (F3)	DeviceNet (E3)
1/4 NPTF	203-1254	203-1238
3/8 NPTF	203-1255	203-1239
1/4 G	203-1256	203-1240
3/8G	203-1257	203-1241

Base Assemblies

Port Size	DeviceLogix (F4)	DeviceNet (E4)
1/4 NPTF	203-1258	203-1242
3/8 NPTF	203-1259	203-1243
1/4 G	203-1260	203-1244
3/8G	203-1261	203-1245



Individual Base Node

Auxiliary Power Replacement Kit

239-2441

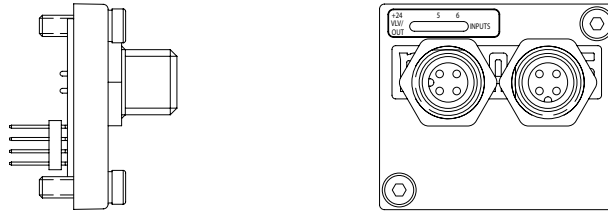

Auxiliary I/O Replacement Kit

239-2440

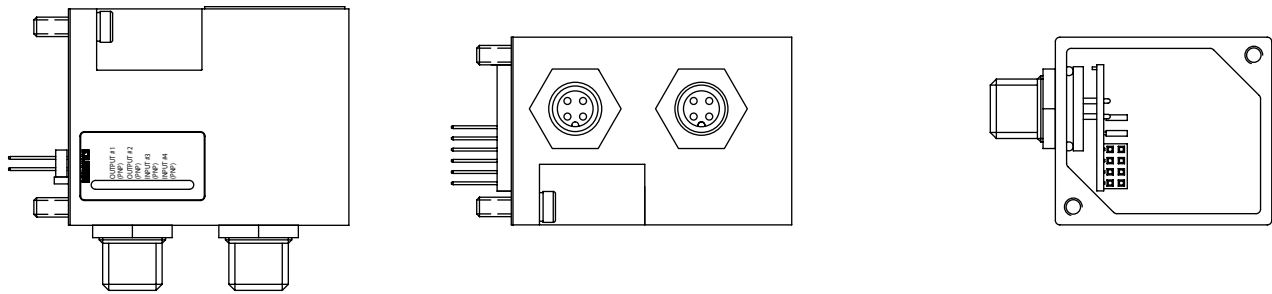

DeviceLogix Node Replacement Kit

239-2438

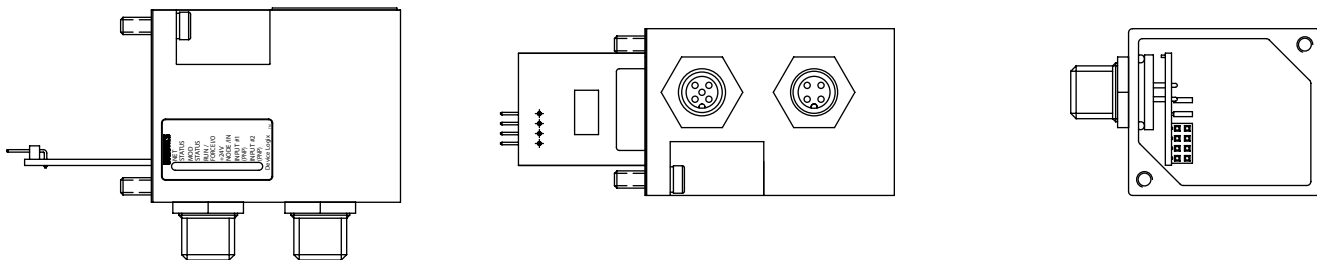

DeviceNet Node Replacement Kit

239-2439

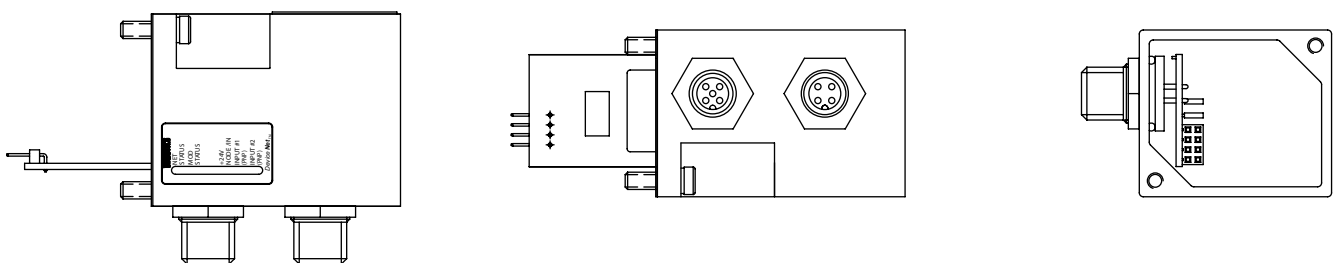



G2-2 Fieldbus Communications Electronics

Direct to PLC manifolds with integrated I/O modules

- No internal wiring simplifies assembly
- Up to 15 discrete I/O points and 16 valve solenoids per manifold
- Plug-together flexibility
- Backplane technology allows fast maintenance
- NEMA 4/IP65 protected against water splash
- DIN rail mountable
- Single multi-conductor cable connection for entire manifold controls valves and I/O





I/O Modules

Technical Data

ELECTRICAL DATA

Inputs:

Voltage	24 VDC
Type	PNP or contact closure
LED Indicator	Input status

Outputs:

Voltage	24 VDC +/- 10%
Current	0.5 amperes per output
Type	Sourcing (PNP)
LED Indicator	Output status

OPERATING DATA

Temperature Range	-10° to +115° F (-23° to +46° C)
Humidity	95% relative humidity, non-condensing
Moisture	Designed to meet NEMA 4 / IP65 requirements
Connectors	Single key 4 pin female 12mm micro, 8 mm PICO and 25 pin Sub-D connectors

CONFIGURATION DATA

	12 mm	8 mm	25 Pin Sub-d
Connectors per Block	4	4	1
I/O Points per Connector	2	1	15
Total I/O points	8	4	15

Note: A direct to PLC I/O manifold assembly must utilize the singular I/O module when there is only (1) I/O module in the assembly. For all assemblies utilizing two or more modules a "left" and a "right hand" module must be used. The "middle" I/O module, if needed, must be used in conjunction with the left and right hand I/O module.



How to Order

1) Assembly Kit Selection

A K D E D 0 0 0 0 3 L STD

Electrical / Electronic Type & Location
 W = 25 Pin Sub-D
 Y = 37 Pin Sub-D
 D = 26 Pin Round Connector

Valve Series
 B = 2035 Series
 E = 2005 or ISO 15407-2 18 mm
 G = 2012 or ISO 15407-2 26 mm
 Q = ISO 5599/2 Size 1
 R = ISO 5599/2 Size 2
 S = ISO 5599/2 Size 3

Number of Valve Stations*

A = 1	I = 9
B = 2	J = 10
C = 3	K = 11
D = 4	L = 12
E = 5	M = 13
F = 6	N = 14
G = 7	O = 15
H = 8	P = 16

Options
 STD = Standard
 DRM = DIN Rail Mounting
 MUF = Muffler in End Plates
 DWM = DIN Rail with MUF
 14X = External Pilot

Port Type
 L = Push In (2005 or 2012 only)
 N = NPTF
 G = Metric

End Plate Port Size
 2** = 2012
 3** = 2012, 2005, & ISO 5599/2 Size 1
 4 = ISO 5599/2 Size 2 & 2035
 6 = ISO 5599/2 Size 3
 H** = 2012
 K** = 2005 or 2012
 ** See chart below

*Maximum number of valve stations is determined by the combination of single and double Z-Boards types installed in the manifold sub-bases.

2005	2012	
3 = 3/8	3 = Port Type G, N, or L	
K = 10mm tube	Port 1 = 3/8	Port 3/5 = 1/2
	2 = Port Type L Only	
	Port 1 = 1/4	Port 3/5 = 3/8
	H = Port Type L Only	
	Port 1 = 8mm	Port 3/5 = 12mm
	K = Port Type L Only	
	Port 1 = 10mm	Port 3/5 = 14mm

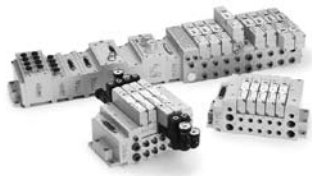

Direct to PLC

When Ordering:

“AKW” Manifold Assembly Kit with Direct to PLC I/O Modules 2005, 2012 & 2035 Series and ISO Series

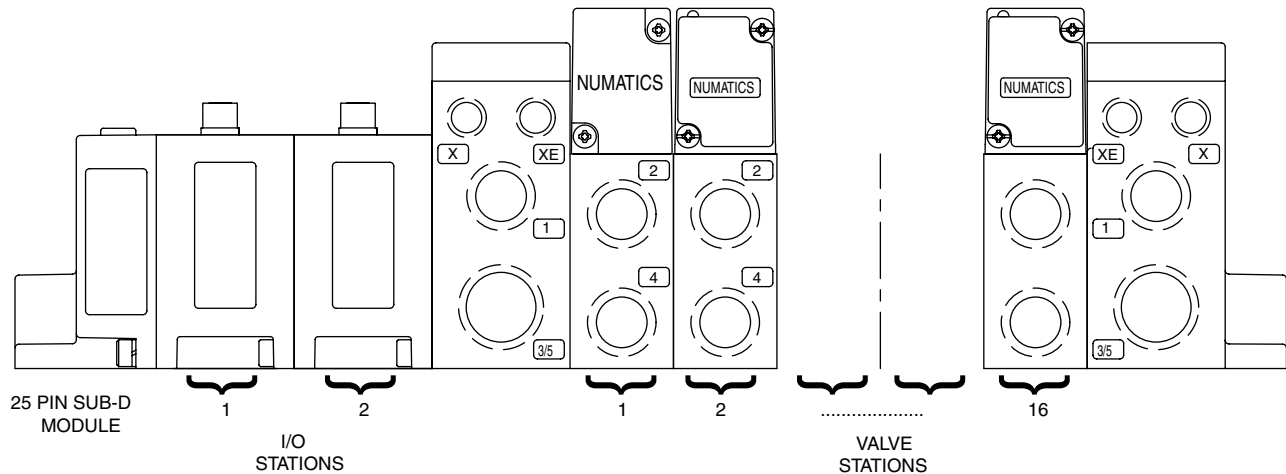

- Each Direct to PLC I/O module station is listed in sequential order from left to right between the “AK” number and the 1st valve station.
- Each valve manifold station is listed in sequential order from left to right when facing the port side of the manifold as indicated
- Total of 16 solenoid outputs are available. Either 16 single solenoid valves or 8 double solenoid valves or any combination of singles and doubles, not to exceed 16 solenoid outputs
- When selecting Direct to PLC I/O modules a “singular” module must be used when there is only one module in the assembly. A “left hand” and “right hand” module must be used when there are two modules in the assembly.
- When utilizing the 25 pin sub-d electrical connection a maximum of 5 discrete I/O points are available.
- Each 12mm I/O block utilizes 8 discrete I/O and each 8mm I/O block utilizes 4 discrete I/O

Example order:

AKWGH00003LSTD

I/O station 1	239-2504 (Left Hand)
I/O station 2	239-2505 (Right Hand)
Valve station 1	123BA4Z2ML00061
Valve station 2	123BA4Z2ML00061
Valve station 3	123BA4Z2ML00061
Valve station 4	123BA4Z2ML00061
Valve station 5	123BA4Z2ML00061
Valve station 6	123BA4Z2ML00061
Valve station 7	123BA4Z2ML00061
Valve station 8	123BA4Z2ML00061
	ASSEMBLED

MANIFOLD ELECTRICAL CONNECTION	NO. OF DISCRETE I/O	CONNECTOR TYPE	NO. OF MODULES	MODULES REQUIRED			
				SINGULAR	LEFT HAND	MIDDLE	RIGHT HAND
25 pin sub-d (AKW)	4	8mm	1 module	239-2503	N/A	N/A	N/A
	5	12mm	1 module	239-2507	N/A	N/A	N/A
	5	Sub-D	1 module	239-2096	N/A	N/A	N/A
	5	8mm	2 modules	N/A	239-2504	N/A	239-2505



Direct to PLC

When Ordering:

“AKY” Manifold Assembly Kit with Direct to PLC I/O Modules 2005, 2012 & 2035 Series and ISO Series

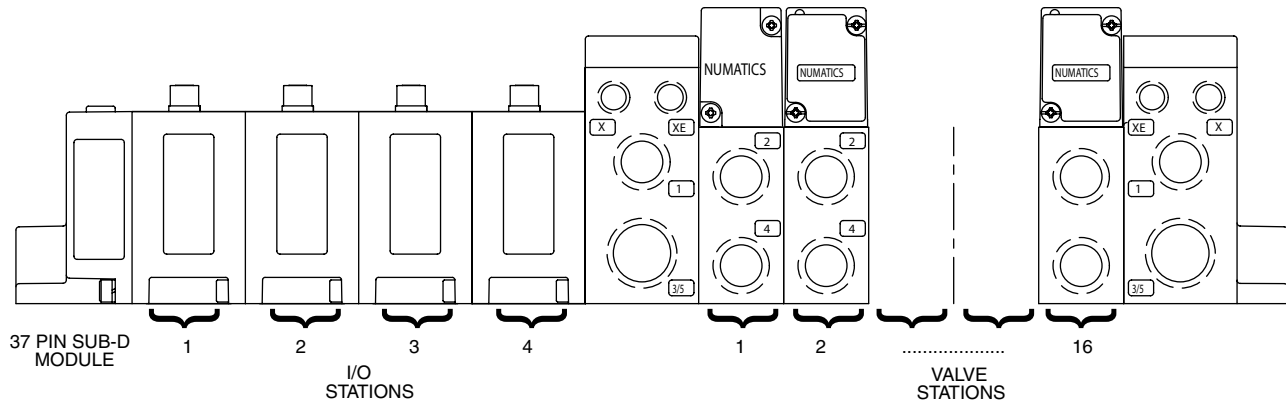

- Each Direct to PLC I/O module station is listed in sequential order from left to right between the “AK” number and the 1st valve station.
- Each valve manifold station is listed in sequential order from left to right when facing the port side of the manifold as indicated
- Total of 16 solenoid outputs are available. Either 16 single solenoid valves or 8 double solenoid valves or any combination of singles and doubles, not to exceed 16 solenoid outputs
- When selecting Direct to PLC I/O modules a “singular” module must be used when there is only one module in the assembly. A “left hand” and “right hand” module must be used when there are two modules in the assembly.
- When utilizing the 37 pin sub-d electrical connection a maximum of 15 discrete I/O points are available.
- Each 12mm I/O block utilizes 8 discrete I/O and each 8mm I/O block utilizes 4 discrete I/O.

Example order:

	AKYGH00003LSTD
I/O station 1	239-2504 (Left Hand)
I/O station 2	239-2506 (Middle)
I/O station 3	239-2506 (Middle)
I/O station 4	239-2505 (Right Hand)
Valve station 1	123BA4Z2ML00061
Valve station 2	123BA4Z2ML00061
Valve station 3	123BA4Z2ML00061
Valve station 4	123BA4Z2ML00061
Valve station 5	123BA4Z2ML00061
Valve station 6	123BA4Z2ML00061
Valve station 7	123BA4Z2ML00061
Valve station 8	123BA4Z2ML00061
	ASSEMBLED

MANIFOLD ELECTRICAL CONNECTION	NO. OF DISCRETE I/O	CONNECTOR TYPE	NO. OF MODULES	MODULES REQUIRED			
				SINGULAR	LEFT HAND	MIDDLE	RIGHT HAND
37 pin sub-d (AKY)	4	8mm	1 module	239-2503	N/A	N/A	N/A
	8	12mm	1 module	239-2507	N/A	N/A	N/A
	15	Sub-D	1 module	239-2096	N/A	N/A	N/A
	8	8mm	2 modules	N/A	239-2504	N/A	239-2505
	15	12mm	2 modules	N/A	239-2508	N/A	239-2509
	12	8mm	3 modules	N/A	239-2504	239-2506	239-2505
	15	8mm	4 modules	N/A	239-2504	(2) 239-2506	239-2505



Direct to PLC

When Ordering:

“AKD” Manifold Assembly Kit with Direct to PLC I/O Modules 2005, 2012 & 2035 Series and ISO Series

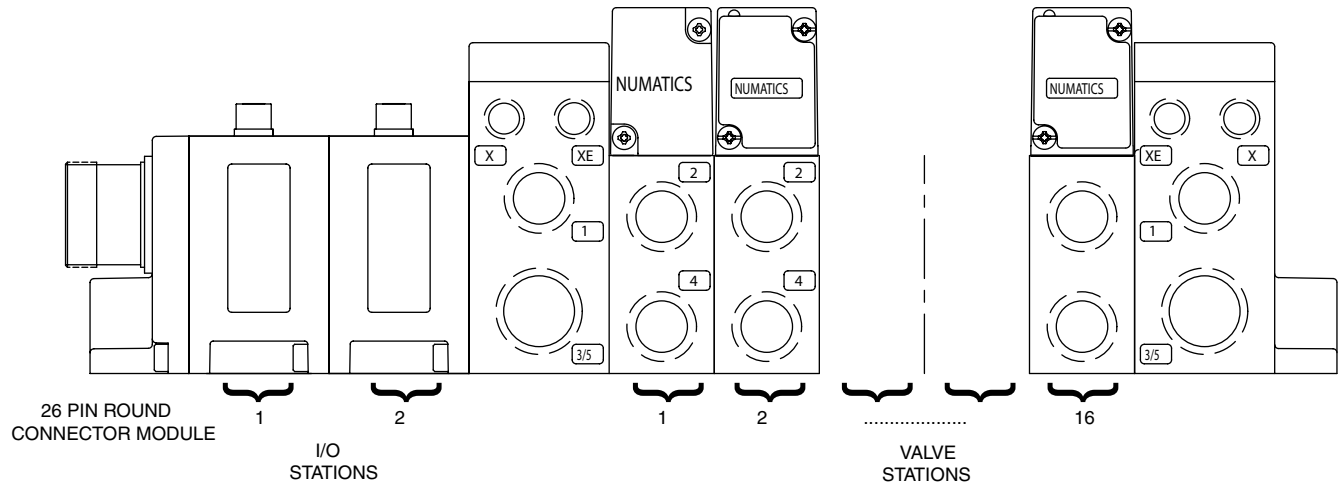

- Each Direct to PLC I/O module station is listed in sequential order from left to right between the “AK” number and the 1st valve station.
- Each valve manifold station is listed in sequential order from left to right when facing the port side of the manifold as indicated
- Total of 16 solenoid outputs are available. Either 16 single solenoid valves or 8 double solenoid valves or any combination of singles and doubles, not to exceed 16 solenoid outputs
- When selecting Direct to PLC I/O modules a “singular” module must be used when there is only one module in the assembly. A “left hand” and “right hand” module must be used when there are two modules in the assembly.
- When utilizing the 26 pin round electrical connection a maximum of 5 discrete I/O points are available.
- Each 12mm I/O block utilizes 8 discrete I/O and each 8mm I/O block utilizes 4 discrete I/O.

Example order:

I/O station 1	AKDGH00003LSTD
I/O station 2	239-2504 (Left Hand)
Valve station 1	239-2505 (Right Hand)
Valve station 2	123BA4Z2ML00061
Valve station 3	123BA4Z2ML00061
Valve station 4	123BA4Z2ML00061
Valve station 5	123BA4Z2ML00061
Valve station 6	123BA4Z2ML00061
Valve station 7	123BA4Z2ML00061
Valve station 8	123BA4Z2ML00061
	ASSEMBLED

MANIFOLD ELECTRICAL CONNECTION	NO. OF DISCRETE I/O	CONNECTOR TYPE	NO. OF MODULES	MODULES REQUIRED			
				SINGULAR	LEFT HAND	MIDDLE	RIGHT HAND
26 pin round (AKD)	4	8mm	1 module	239-2503	N/A	N/A	N/A
	5	12mm	1 module	239-2507	N/A	N/A	N/A
	5	Sub-D	1 module	239-2096	N/A	N/A	N/A
	5	8mm	2 modules	N/A	239-2504	N/A	239-2505



12mm I/O Module Assemblies

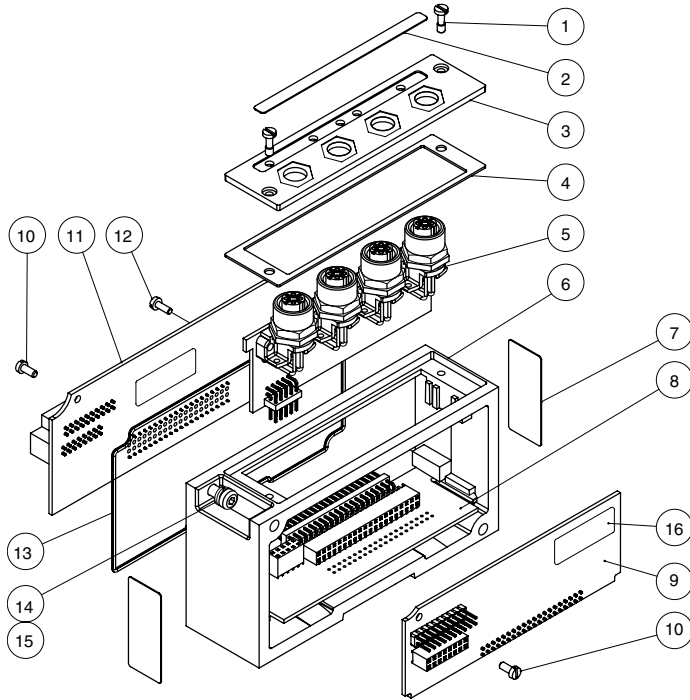

DET. NO.	NO. REQ'D	PART NAME	PART NO.
1	2	Screw	127-852
2	1	Lens	122-1076
3	1	Cover	105-468
4	1	Gasket	113-532
5	1	M8 I/O Board	256-944
6	1	Housing	125-1135
7	2	Label	122-1057
8	1	Transition Backplane Board	256-943
9	1	Transition Board	256-939
10	2	Screw	127-794
11	1	Converter Board	256-671
12	1	Ground Screw	127-318
13	1	Gasket	113-531
14	2	Screw	127-697
15	2	Lockwasher	128-188
16	4	Label	122-770

	SINGULAR	LEFT HAND	RIGHT HAND
Module	239-2507	239-2508	239-2509
Replacement Board	240-108	240-108	240-108

8 mm I/O Module Assemblies

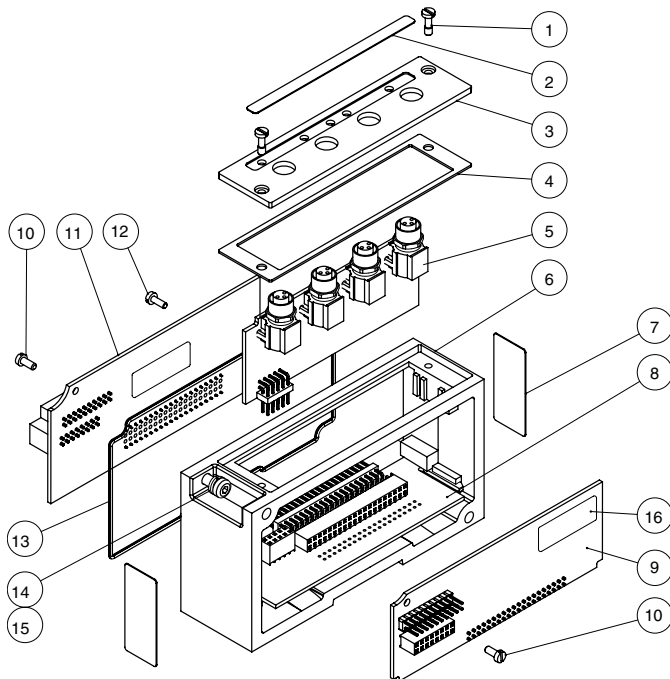

DET. NO.	NO. REQ'D	PART NAME	PART NO.
1	2	Screw	127-852
2	1	Lens	122-1216
3	1	Cover	105-467
4	1	Gasket	113-532
5	1	M8 I/O Board	256-940
6	1	Housing	125-1135
7	2	Label	122-1057
8	1	Transition Backplane Board	256-941
9	1	Transition Board	256-939
10	2	Screw	127-794
11	1	Converter Board	256-671
12	1	Ground Screw	127-318
13	1	Gasket	113-531
14	2	Screw	127-697
15	2	Lockwasher	128-188
16	4	Label	122-770

	SINGULAR	LEFT HAND	RIGHT HAND	MIDDLE
Module	239-2503	239-2504	239-2505	239-2506
Replacement Board	256-940	256-940	256-940	256-940



25 Pin Sub-D I/O Module Assembly Input/Output Module Kit

239-2096

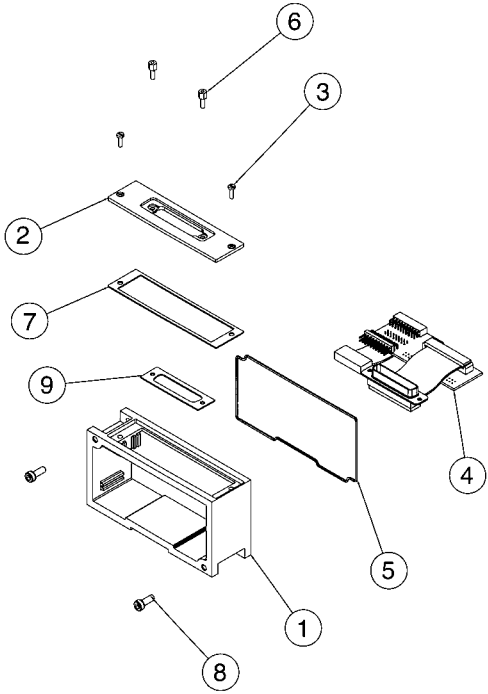

DET. NO.	NO. REQ'D	PART NAME	PART NO.
1	1	Housing	125-801
2	1	Cover	105-427
3	2	Screw	127-852
4	1	P.C. Board Assembly	256-741
5	1	Gasket	113-531
6	2	Jack Screw	127-825
7	1	Gasket	113-532
8	2	Screw	127-697
9	1	Gasket	113-507

M27 26 Pin Round Connector Kit

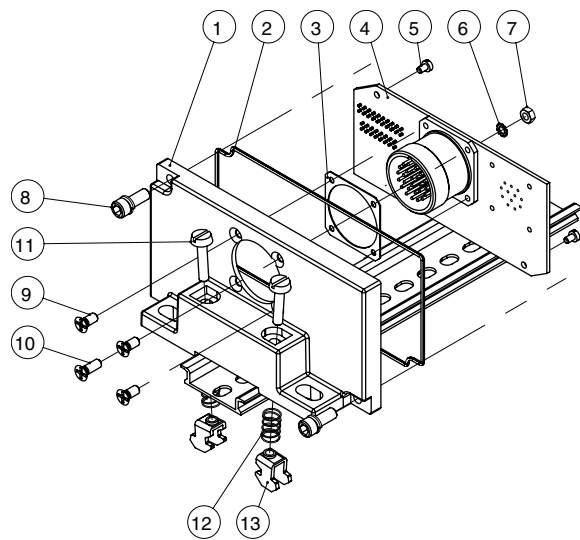

26 PIN ROUND CONNECTOR
 PINS 1-16= OUTPUTS
 PIN 17=+24VDC
 PINS 18-22= I/O POINTS
 PINS 24,25= 0VDC
 PIN 26= EARTH GROUND
 239-2511

26 Pin ROUND CONNECTOR KIT	PART NO.
Without Din	239-2510
With Din	239-2511

DET. NO.	NO. REQ'D	PART NAME	PART NO.
1	1	Cover	105-408
2	1	Gasket	113-531
3	1	Gasket	113-353
4	1	26 Pin PCB Assy	156-624
5	2	Screw	127-875
6	1	Lock Washer	128-294
7	1	Hex Nut	128-293
8	2	Screw Assy	127-396
9	3	Screw	127-810
10	1	Screw	127-770
11	2	Screw (DIN RAL Only)	127-742
12	2	Spring (DIN RAL Only)	115-355
13	2	Clamp (DIN RAL Only)	125-720



25 Pin Sub-D Connector Kit

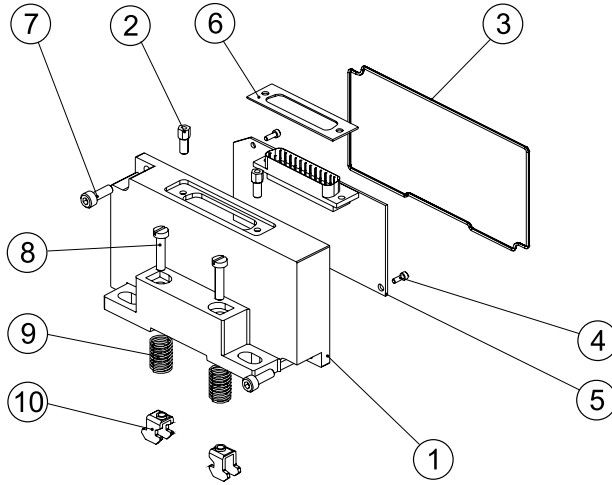

25 PIN SUB-D CONNECTOR
 PINS 1-16= OUTPUTS
 PIN 17=+24VDC
 PINS 18-22= I/O POINTS
 PINS 23,24= 0VDC
 PIN 25= EARTH GROUND ⚡

NOTE: External fusing or output protection recommended.

25 PIN SUB-D HOUSING KITS		PART NO.
Without DIN Rail		239-2097
With DIN Rail		239-2513

DET. NO.	NO. REQ'D	PART NAME	PART NO.
1	1	Housing	105-401
2	2	Hex Screw	127-825
3	1	Gasket	113-531
4	2	Screw	127-318
5	1	PCB Ass'y	256-607
6	1	Gasket	113-507
7	2	Screw Ass'y	127-396
8	2	Screw (DIN Rail Only)	127-472
9	2	Spring (DIN Rail Only)	115-355
10	2	Clamp (DIN Rail Only)	125-720

37 Pin Sub-D Connector Kit

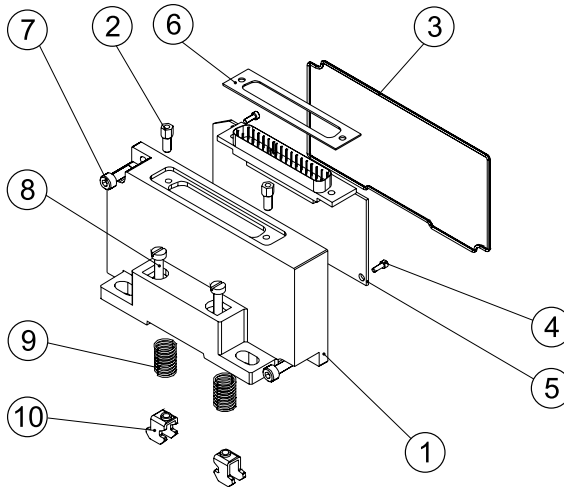

37 PIN SUB-D CONNECTOR
 PINS 1-16= OUTPUTS
 PIN 17=+24VDC
 PINS 18-32= I/O POINTS
 PINS 33-36= 0VDC
 PIN 37= EARTH GROUND ⚡

NOTE: External fusing or output protection recommended.

37 PIN SUB-D HOUSING KITS		PART NO.
Without DIN Rail		239-2098
With DIN Rail		239-2512

DET. NO.	NO. REQ'D	PART NAME	PART NO.
1	1	Housing	105-402
2	2	Hex Screw	127-825
3	1	Gasket	113-531
4	2	Screw	127-318
5	1	PCB Ass'y	256-608
6	1	Gasket	113-530
7	2	Screw Ass'y	127-396
8	2	Screw (DIN Rail Only)	127-472
9	2	Spring (DIN Rail Only)	115-355
10	2	Clamp (DIN Rail Only)	125-720

4 Pin MINI Power Cables for G2-2 Electronics

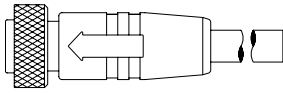

FEMALE 4 Pin STRAIGHT 18 AWG EURO COLOR CODE

1 Meter - MC0401MAF0000000

2 Meter - MC0402MAF0000000

5 Meter - MC0405MAF0000000

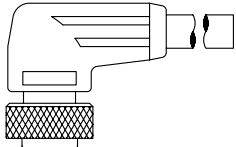

FEMALE 4 Pin 90° 18 AWG EURO COLOR CODE

1 Meter - MD0401MAF0000000

2 Meter - MD0402MAF0000000

5 Meter - MD0405MAF0000000

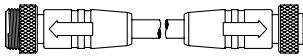
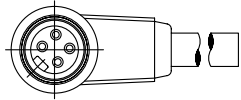

F/M 4 PIN STRAIGHT 18 AWG EURO COLOR CODE

1 Meter - MC0401MAFMA04000

2 Meter - MC0402MAFMA04000

5 Meter - MC0405MAFMA04000

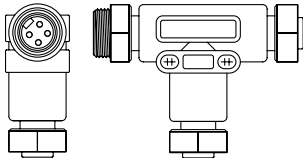

4 PIN "T"

MC0400000MT04000

MINI 4 Pin Pin-Out

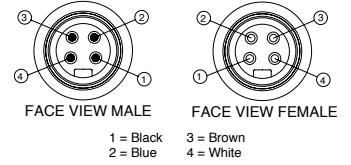

TECHNICAL DATA

Molded Body / Insert	PUR
Coupling Nut	Aluminum
Cable	PVC
Cable O.D.	0.290
Voltage Rating	300 V
Amperage	5.6 A
Protection	IP 68, NEMA 6P
Operating Temperature	-40°C to 90°C



4 Pin 12mm (M12) Power Cables for G2-1 Electronics

12mm 4 Pin Pin-Out

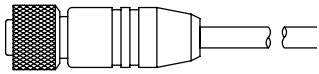
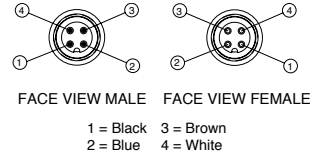

FEMALE 4 PIN STRAIGHT 18 AWG EURO COLOR CODE

1 Meter - TC0401MAE000000

2 Meter - TC0402MAE000000

5 Meter - TC0405MAE000000

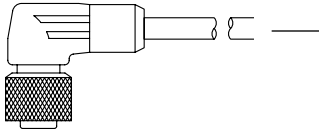

FEMALE 4 PIN 90° 18 AWG EURO COLOR CODE

1 Meter - TD0401MAE000000

2 Meter - TD0402MAE000000

5 Meter - TD0405MAE000000

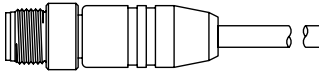

MALE 4 PIN STRAIGHT 18 AWG EURO COLOR CODE

1 Meter - TA0401MAE000000

2 Meter - TA0402MAE000000

5 Meter - TA0405MAE000000

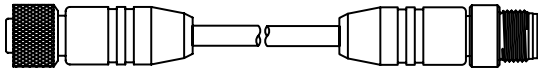

F/M 4 PIN STRAIGHT 18 AWG EURO COLOR CODE

1 Meter - TC0401MAETA04000

2 Meter - TC0402MAETA04000

5 Meter - TC0405MAETA04000

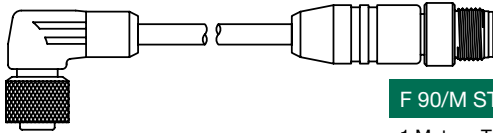

F 90/M STRAIGHT 18 AWG EURO COLOR CODE

1 Meter - TD0401MAETA04000

2 Meter - TD0402MAETA04000

5 Meter - TD0405MAETA04000

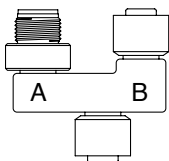

4/5 PIN "T" (POWER)

TC050000TT05000

TECHNICAL DATA

Molded Body / Insert	PUR
Coupling Nut	"T" - Aluminum
	Cables - Brass, Nickel Plated
Cable	PUR
Cable O.D.	0.190"
Voltage Rating	250 V
Amperage	4.0 A
Protection	IP 68, NEMA 6P
Operating Temperature	-40°C to 90°C

Field Attachable Connectors 3, 4, and 5 Pin

MINI

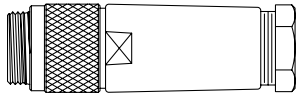

4 Pin MINI MALE STRAIGHT

PG 9 Cable Gland - MA04F20000000000

PG 13.5 Cable Gland - MA04F300000000000

5 Pin MINI MALE STRAIGHT

PG 9 Cable Gland - MA05F200000000000

PG 13.5 Cable Gland - MA05F300000000000

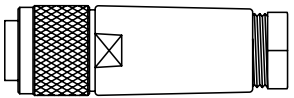

4 Pin MINI FEMALE STRAIGHT

PG 9 Cable Gland - MC04F200000000000

PG 13.5 Cable Gland - MC04F300000000000

5 Pin MINI FEMALE STRAIGHT

PG 9 Cable Gland - MC05F200000000000

PG 13.5 Cable Gland - MC05F300000000000

5 Pin MINI FEMALE STRAIGHT FOR RIO COMMUNICATION

PG 13.5 Cable Gland - MC05M200000000000

12mm (M12)

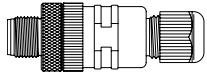

4 Pin 12mm MALE STRAIGHT

PG 7 Cable Gland - TA04F100000000000

PG 9 Cable Gland - TA04F200000000000

5 Pin 12mm MALE STRAIGHT

PG 7 Cable Gland - TA05F100000000000

PG 9 Cable Gland - TA05F200000000000

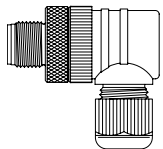

4 Pin 12mm MALE 90 DEGREE

PG 7 Cable Gland - TB04F100000000000

PG 9 Cable Gland - TB04F200000000000

5 Pin 12mm MALE 90 DEGREE

PG 7 Cable Gland - TB05F100000000000

PG 9 Cable Gland - TB05F200000000000

TECHNICAL DATA

Molded Body / Insert	Glass Filled Nylon/Nylon
Coupling Nut	Aluminum
Cable Range	PG9: 0.157-0.315 PG13.5: 0.394-0.472
Voltage Rating	600 V
Amperage	4 Pole - 9 A 5 Pole - 9 A
Protection	IP 67, NEMA 6P
Operating Temperature	-40°C to 90°C

MINI 4 Pin Pin-Out

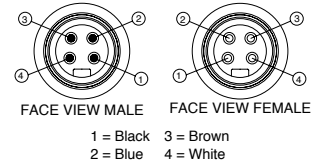

MINI 5 Pin Pin-Out

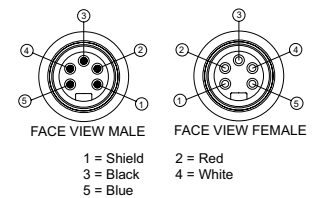

– REMOTE I/O

12mm 4 Pin Pin-Out

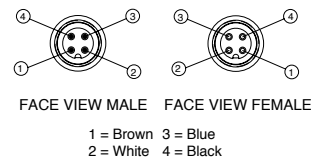

12mm 5 Pin Pin-Out

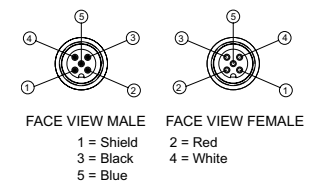



Field Attachable Connectors 3, 4, and 5 Pin continued

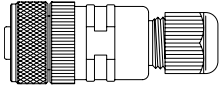

4 Pin 12mm FEMALE STRAIGHT

PG 7 Cable Gland - TC04F10000000000

PG 9 Cable Gland - TC04F20000000000

5 Pin 12mm FEMALE STRAIGHT

PG 7 Cable Gland - TC05F10000000000

PG 9 Cable Gland - TC05F20000000000

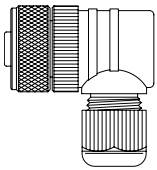

4 Pin 12mm FEMALE 90 DEGREE

PG 7 Cable Gland - TD04F10000000000

PG 9 Cable Gland - TD04F20000000000

5 Pin 12mm FEMALE 90 DEGREE

PG 7 Cable Gland - TD05F10000000000

PG 9 Cable Gland - TD05F20000000000

8mm (M8)

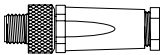

3 Pin 8mm MALE STRAIGHT

Cable Dia. 0.138 to 0.197 - PA03F00000000000

4 Pin 8mm MALE STRAIGHT

Cable Dia. 0.138 to 0.197 - PA04F00000000000

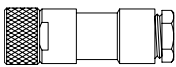

3 Pin 8mm FEMALE STRAIGHT

Cable Dia. 0.138 to 0.197 - PC03F000000000000

4 Pin 8mm FEMALE STRAIGHT

Cable Dia. 0.138 to 0.197 - PC04F00000000000

8mm 3 Pole Pin-Out

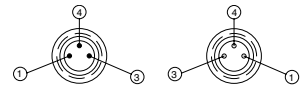

FACE VIEW MALE FACE VIEW FEMALE

8mm 4 Pole Pin-Out

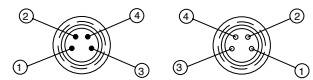

FACE VIEW MALE FACE VIEW FEMALE

TECHNICAL DATA - Micro 12 mm / Pico 8 mm

12 mm Molded Body	Nylon
8 mm Molded Body	TPU
Insert	Nylon
Coupling Nut	12 mm Brass, Nickel Plated, 8 m CuZn, brass, nickeled
Cable Range	PG7: 0.119 - 0.255 PG9: 0.157 - 0.315 Pico 8 mm: 0.138 - 0.197
Voltage Rating	12 mm: 250 V 8 mm: 60 VAC/75 VDC
Amperage	4.0 A
Protection	IP 67, NEMA 6 (12 mm only)
Operating Temperature	-25°C to 85°C



DeviceNet Trunk Cables, Drop Cables and Accessories

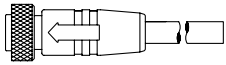

FEMALE MINI THICK CABLE

3 Foot - MC0503FFD0000000

6 Foot - MC0506FFD0000000

12 Foot - MC0512FFD0000000

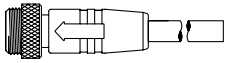

MALE MINI THICK CABLE

3 Foot - MA0503FFD0000000

6 Foot - MA0506FFD0000000

12 Foot - MA0512FFD0000000



FEMALE TO MALE MINI THICK CABLE EXTENSION

3 Foot - MC0503FFDMA05000

6 Foot - MC0506FFDMA05000

12 Foot - MC0512FFDMA05000

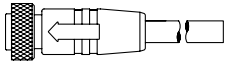

FEMALE MINI THIN CABLE

3 Foot - MC0503FGD0000000

6 Foot - MC0506FGD0000000

12 Foot - MC0512FGD0000000

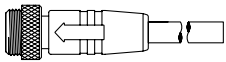

MALE MINI THIN CABLE

3 Foot - MA0503FGD0000000

6 Foot - MA0506FGD0000000

12 Foot - MA0512FGD0000000



FEMALE TO MALE MINI THIN CABLE EXTENSION

3 Foot - MC0503FGDMA05000

6 Foot - MC0506FGDMA05000

12 Foot - MC0512FGDMA05000

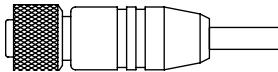

FEMALE 12mm THIN CABLE

3 Foot - TC0503FGD0000000

6 Foot - TC0506FGD0000000

12 Foot - TC0512FGD0000000

MINI Device Net 5 Pin Pin-Out

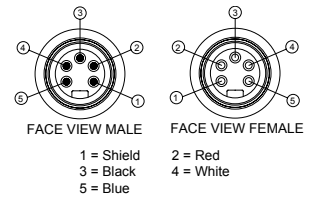

12mm Device Net 5 Pin Pin-Out

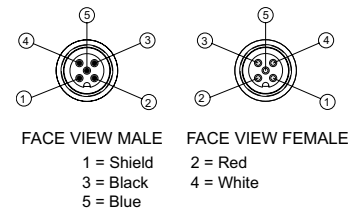



DeviceNet Trunk Cables, Drop Cables and Accessories continued

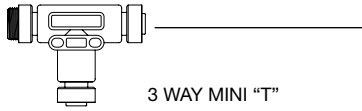

DEVICENET T'S

3 Way MINI "T" - MC0500000MT05000

3 Way MINI - 12mm "T" - TC0500000MT05000

3 Way 12mm "T" - TC0500000TT05000

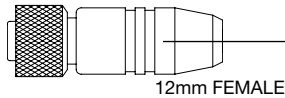
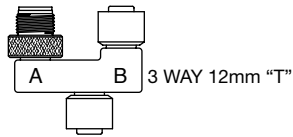
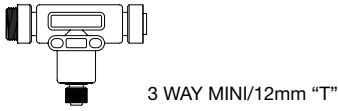

TERMINATING RESISTORS

12mm Female - TC05TR00000000

12mm Male - TA05TR00000000

MINI Female - MC05TR00000000

MINI Male - MA05TR00000000

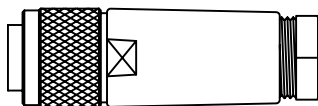
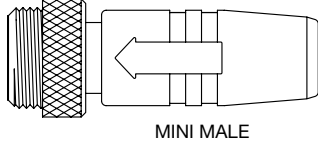
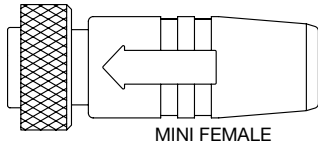
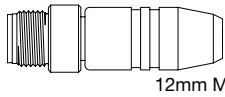

FEMALE MINI FIELD ATTACHABLE

PG 9 Cable Gland - MC05F200D0000000

PG 13.5 Cable Gland - MC05F300D0000000

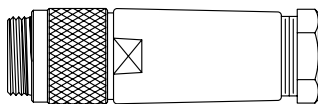

MALE MINI FIELD ATTACHABLE

PG 9 Cable Gland - MA05F200D0000000

PG 13.5 Cable Gland - MA05F300D0000000

MALE MINI FIELD ATTACHABLE

Molded Body / Insert

PUR

Coupling Nut

Mini - Aluminum

Micro - Nickel Plated Brass

Cable

PVC

Cable O.D.

Thick - 0.475" Thin - 0.275"

Voltage Rating

Mini - 300 V Micro - 150 V

Amperage

Thick - 8.0 A Thin - 2.4 A

Protection

IP 68, NEMA 6P

Operating Temperature

-20 C to 90 C

NOTE: Color coded for DeviceNet.

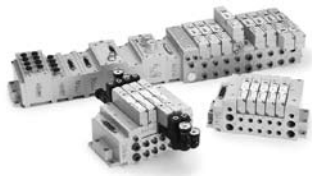

Profibus Cables and Accessories (Reverse Key)

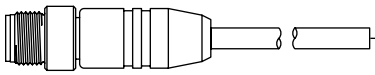

MALE 12mm REVERSE KEY SINGLE ENDED

1 Meter - RA0501MHP0000000

2 Meter - RA0502MHP0000000

5 Meter - RA0505MHP0000000

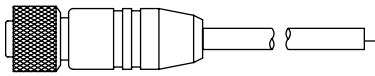

FEMALE 12mm REVERSE KEY SINGLE ENDED

1 Meter - RC0501MHP0000000

2 Meter - RC0502MHP0000000

5 Meter - RC0505MHP0000000

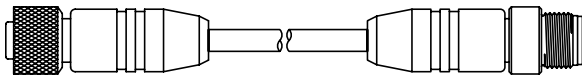

F/M 12mm REVERSE KEY DOUBLE ENDED

1 Meter - RC0501MHPRA05000

2 Meter - RC0502MHPRA05000

5 Meter - RC0505MHPRA05000

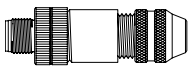

MALE

FIELD ATTACHABLE CONNECTORS

Male - RA05F200P0000000

Female - RC05F200P0000000

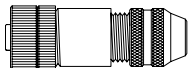

FEMALE

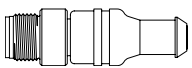

TERMINATING RESISTORS

Male - RA05TR00000000

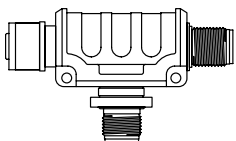

BUS "T"

RA050000PRT05000

12mm Profibus Reverse Key 5 Pin Pin-Out

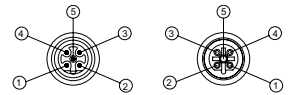

FACE VIEW MALE FACE VIEW FEMALE

1 = N/C 2 = Green
3 = N/C 3 = Red
5 = Shield

TECHNICAL DATA

Molded Body / Insert	Cable=PUR, Field Attachable=PA
Coupling Nut	Nickel Plated
Cable	PUR
Voltage Rating	Cable=250 V, Field Attachable=30 VAC/36 VDC
Amperage	Field Attachable=4.0 A
Protection	Cable=IP67/68/NEMA 6P, Field Attachable=IP67
Operating Temperature	-40°C to 80°C Static, -5° to 80°C Moving
Cable Range	0-16" - 0.240"



AS-i Cables/Connectors

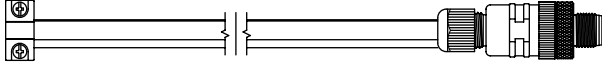

AS-i Addressing Cable – 3 feet

230-1171

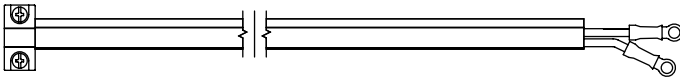

AS-i Power Cable – 3 feet

230-1172



AS-i Connector

230-1036

TECHNICAL DATA	Vampire Connector	12 mm Connector	AS-i Cable
Molded Body / Insert	PUR	Nylon	N/A
Coupling Nut	N/A	Brass, Ni Plated	N/A
Cable	N/A	N/A	EPR (ethylene-propylene)
Cable O.D.	N/A	4-8 mm	2x1.5 mm ²
Voltage Rating	N/A	125 V	N/A
Amperage	N/A	4.0 A	N/A
Degree of Protection	IP67	IP67	IP67
Operating Temp	-20°C – +70°C	-30°C – +85°C	-30°C – +90°C



Ethernet Cables - RJ45

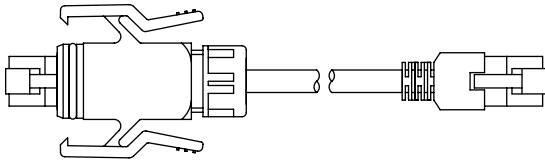

RJ45 to IP65 RJ45 Ethernet Cables – Double Ended (Line)

5 Meter VA0805MK0YA08000

10 Meter VA0810MK0YA08000

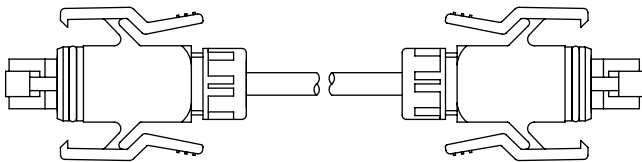

RJ45 to IP65 RJ45 Ethernet Cables – Double Ended (Crossover)

5 Meter VA0805ML0YA08000

10 Meter VA0810ML0YA08000

IP65 RJ45 Ethernet Cables – Double Ended (Line)

5 Meter YA0805MK0YA08000

10 Meter YA0810MK0YA08000

IP65 RJ45 Ethernet Cables – Double Ended (Crossover)

5 Meter YA0805ML0YA08000

10 Meter YA0810ML0YA08000

Ethernet Cables - 12 mm (M12) D-Coded

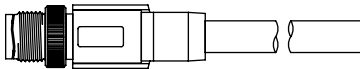

Ethernet 4 Pin D-Coded 12 mm – Single Ended

5 Meter QA0405MK00000000

10 Meter QA0410MK00000000

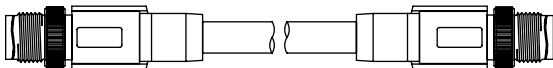

Ethernet 4 Pin D-Coded 12 mm – Double Ended

5 Meter QA0405MK0QA04000

10 Meter QA0410MK0QA04000

12 mm EtherNet IP 4 Pin D-Coded MALE

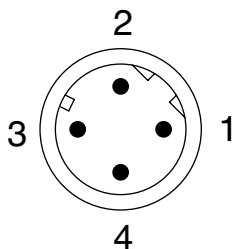

Face View MALE

PIN 1 = White/Orange = TD +

PIN 2 = White/Green = RD +

PIN 3 = Orange = TD -

PIN 4 = Green = RD -

Technical Data	RJ45 Cable	12 mm Cable
Molded Body/Insert	PA	PUR
Coupling Nut	N/A	Brass, Ni Plated
Cable	HM2	PUR
Cable O.D.	.220" to .232"	.320"
Voltage Rating	N/A	125 V
Amperage	N/A	4.0 A
Degree of Protection	IP67	IP65
Operating Temp	0°C – 70°C	0°C – 50°C



I/O Cables, Splitters and Accessories

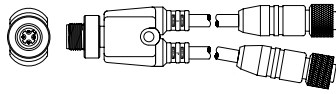

12mm DC SPLITTER 2 STRAIGHT 12mm FEMALE CONNECTORS

1 Meter - TA0401MC0JC05000

2 Meter - TA0402MC0JC05000

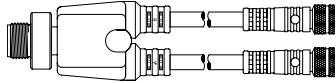

12mm DC SPLITTER 2 STRAIGHT 8mm FEMALE CONNECTORS

1 Meter - TA0401MI0KC03000

2 Meter - TA0402MI0KC03000

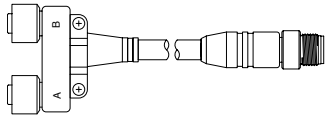

12mm DC "Y" WITH MALE CABLE

0.3 Meter - TA0401FJ0FC04000

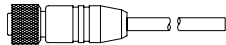

12mm FEMALE 4 PIN STRAIGHT 22 AWG EURO COLOR CODE

2 Meter - TC0402MCE0000000

5 Meter - TC0405MCE0000000

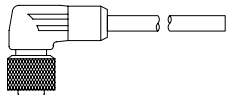

12mm FEMALE 4 PIN 90 DEGREE 22 AWG EURO COLOR CODE

2 Meter - TD0402MCE0000000

5 Meter - TD0405MCE0000000

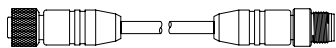

12mm F/M 4 PIN STRAIGHT 22 AWG EURO COLOR CODE

1 Meter - TC0401MC0TA04000

2 Meter - TC0402MC0TA04000

5 Meter - TC0405MC0TA04000

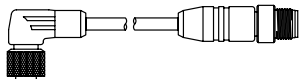

12mm F 90°/M STRAIGHT 22 AWG EURO COLOR CODE

1 Meter - TD0401MC0TA04000

2 Meter - TD0402MC0TA04000

5 Meter - TD0405MC0TA04000



12mm MALE 4 PIN STRAIGHT 22 AWG EURO COLOR CODE

2 Meter - TA0402MCE0000000

5 Meter - TA0405MCE0000000

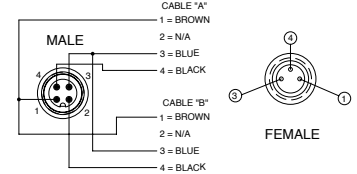
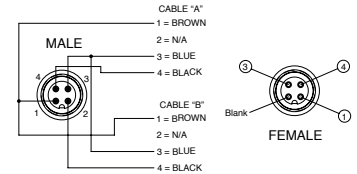

WIRING SCHEMATIC

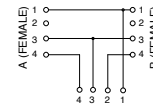

MALE CONNECTOR

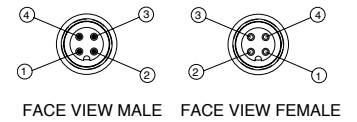
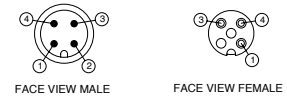

1 = Brown 3 = Blue
2 = White 4 = Black



I/O Cables, Splitters and Accessories continued

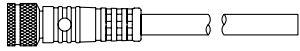

8mm FEMALE 3 PIN STRAIGHT 26 AWG EURO COLOR CODE

2 Meter - PC0302MEE0000000

5 Meter - PC0305MEE0000000

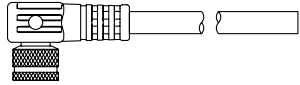

8mm FEMALE 3 PIN 90° 26 AWG EURO COLOR CODE

2 Meter - PD0302MEE0000000

5 Meter - PD0305MEE0000000

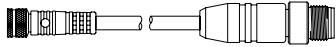

12mm MALE/8mm FEMALE 3 PIN 26 AWG EURO COLOR CODE

2 Meter - TA0302ME0PC03000

5 Meter - TA0305ME0PC03000

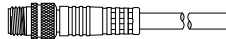

8mm MALE 3 PIN STRAIGHT 26 AWG EURO COLOR CODE

2 Meter - PA0302MEE0000000

5 Meter - PA0305MEE0000000

8mm 3 Pin Pin-Out

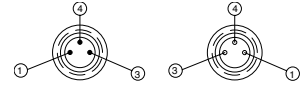

FACE VIEW MALE FACE VIEW FEMALE

1 = Brown 3 = Blue
4 = Black



M23 & M27 Round Cable Assemblies

M23 12 Pin Cables – Single Ended

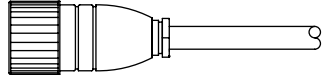

M23 12 Pin Cable Assy., Female, 22 AWG

5 Meter	CC1205MI00000000
10 Meter	CC1210MI00000000
Female Connector (solder cups)	CC12000000000000

M23 12 Pin Cables – Double Ended

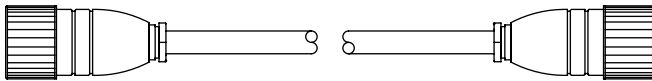

M23 12 Pin Cable Assy., Female-to-Male, 22 AWG

2 Meter	CC1202MI0CE12000
5 Meter	CC1205MI0CE12000
10 Meter	CC1210MI0CE12000

M23 19 Pin Cables – Single Ended

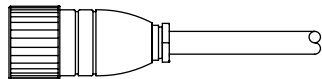

M23 19 Pin Cable Assy., Female, 22 AWG

5 Meter	CC1905MI00000000
10 Meter	CC1910MI00000000
Female Connector (solder cups)	CC19000000000000

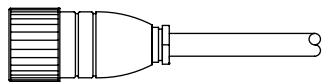

M23 19 Pin Cable Assy., Male, 22 AWG

5 Meter	CE1905MI00000000
10 Meter	CE1910MI00000000

M23 19 Pin Cables – Double Ended

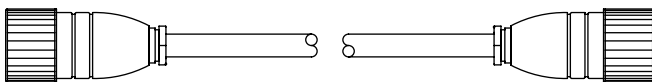

M23 19 Pole Cable Assy., Female-to-Male, 22 AWG

2 Meter	CC1902MI0CE19000
5 Meter	CC1905MI0CE19000
10 Meter	CC1910MI0CE19000

M23-12 Pin Connector Configuration

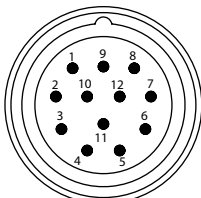

Female

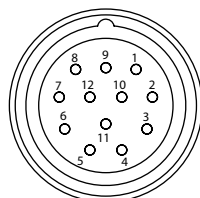

Male

M23-19 Pin Connector Configuration

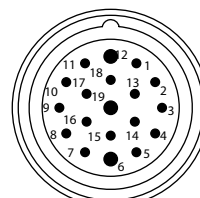

Female

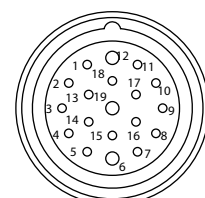

Male



M23 & M27 Round Cable Assemblies

M27 26 Pin Cables – Single Ended

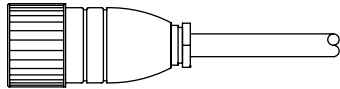

M27 26 Pin Cable Assy., Female, 22 AWG

5 Meter	CC2605MI00000000
10 Meter	CC2610MI00000000
Female Connector (solder cups)	CC26000000000000

M27 26 Pin Cables – Double Ended

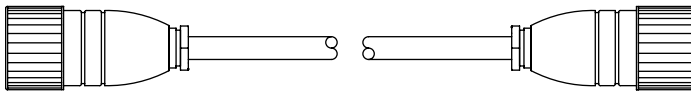

M27 26 Pin Cable Assy., Female-to-Male, 22 AWG

2 Meter	CC2602MI0CE26000
5 Meter	CC2605MI0CE26000
10 Meter	CC2610MI0CE26000

26 Pin Connector Configuration

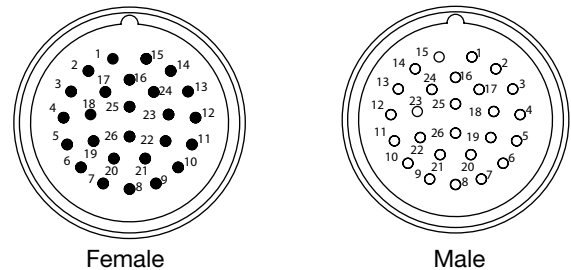

Female

Male

Note: Go to www.numatics.com/wiringdiagrams for wiring information

Pin Out Color Code for M23 & M27 Cables

M23 Cables		M27 Cables	
Pin #1	White	Pin #1	White
Pin #2	Brown	Pin #2	Brown
Pin #3	Green	Pin #3	Green
Pin #4	Yellow	Pin #4	Yellow
Pin #5	Gray	Pin #5	Gray
Pin #6	Pink	Pin #6	Pink
Pin #7	Blue	Pin #7	Blue
Pin #8	Red	Pin #8	Green/Yellow
Pin #9	Black	Pin #9	Black
Pin #10	Purple	Pin #10	Purple
Pin #11	Gray/Pink	Pin #11	Gray/Pink
Pin #12	Green/Yellow	Pin #12	Red/Blue
Pin #13	White/Green	Pin #13	White/Green
Pin #14	Brown/Green	Pin #14	Brown/Green
Pin #15	White/Yellow	Pin #15	White/Yellow
Pin #16	Yellow/Brown	Pin #16	Yellow/Brown
Pin #17	White/Grey	Pin #17	White/Grey
Pin #18	Gray/Brown	Pin #18	Gray/Brown
Pin #19	Red/Blue	Pin #19	White/Pink
		Pin #20	Pink/Brown
		Pin #21	White/Blue
		Pin #22	Brown/Blue
		Pin #23	White/Red
		Pin #24	Brown/Red
		Pin #25	White/Black
		Pin #26	Brown/Black

Technical Data

Molded Body/Insert	PUR
Coupling Nut	Brass, Ni Plated
Cable	PUR
Cable O.D.	.220"
Voltage Rating	150 V
Amperage	8.0 A
Degree of Protection	IP68 (mated)
Operating Temp	40°C – 125°C
Wire AWG	22



Sub-D Cables

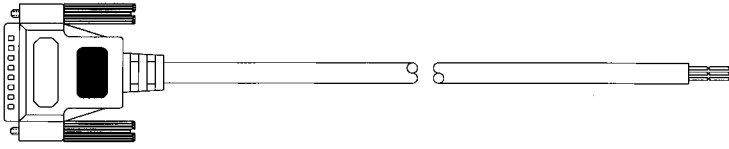

25 Pin SUB-D MALE CABLE 22 AWG - UNSHIELDED

2 Meter - SA2502MCX0000000

5 Meter - SA2505MCX0000000

10 Meter - SA2510MCX0000000

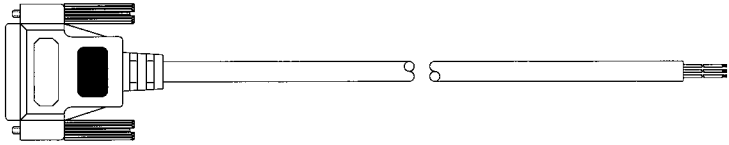

25 Pin SUB-D FEMALE CABLE 22 AWG - UNSHIELDED

2 Meter - SC2502MCX0000000

5 Meter - SC2505MCX0000000

10 Meter - SC2510MCX0000000

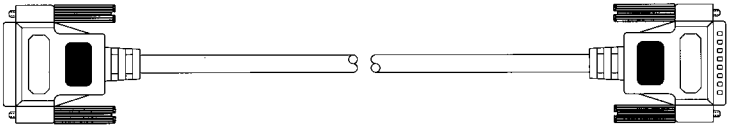

25 Pin SUB-D MALE/FEMALE CABLE 22 AWG - UNSHIELDED

2 Meter - SA2502MCXSC25000

5 Meter - SA2505MCXSC25000

10 Meter - SA2510MCXSC25000

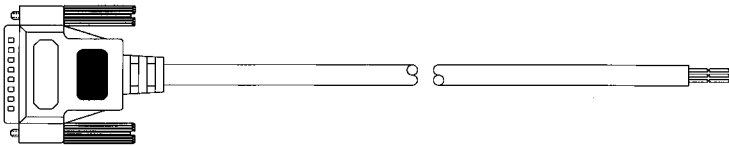

25 Pin SUB-D MALE CABLE 24 AWG - SHIELDED

2 Meter - SA2502MDX0000000

5 Meter - SA2505MDX0000000

10 Meter - SA2510MDX0000000

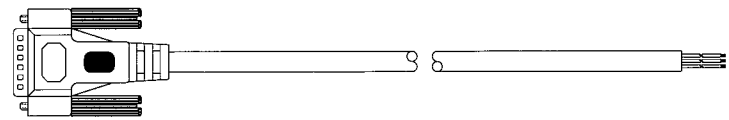

15 Pin SUB-D MALE CABLE 24 AWG - SHIELDED

2 Meter - SA1502MDX0000000

5 Meter - SA1505MDX0000000

10 Meter - SA1510MDX0000000

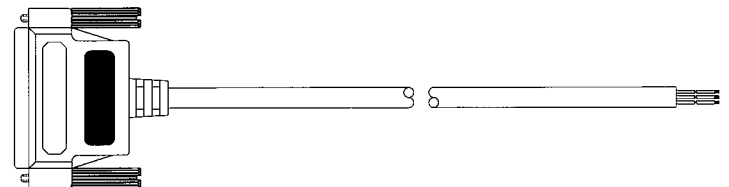

37 Pin SUB-D FEMALE CABLE 22 AWG - UNSHIELDED

2 Meter - SC3702MCX0000000

5 Meter - SC3705MCX0000000

10 Meter - SC3710MCX0000000

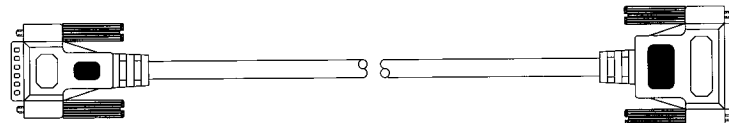

15 Pin MALE/25 Pin FEMALE SUB-D CABLE 22 AWG - UNSHIELDED

2 Meter - SA1502MCXSC25000

5 Meter - SA1505MCXSC25000

10 Meter - SA1510MCXSC25000

Go to www.numatics.com/wiringdiagrams for wiring information



Sub-D Cables continued

25 Pin-Out

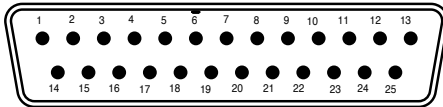

15 Pin-Out

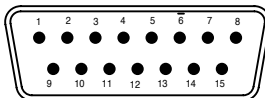

37 Pin-Out

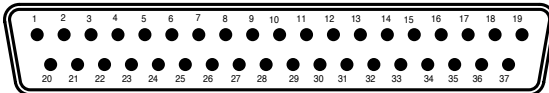

TECHNICAL DATA

Connector Body	PVC
Cable	PVC
Cable O.D. (Approx.)	37 Conductor, 22 AWG - 0.432"
Cable O.D. (Approx.)	25 Conductor, 22 AWG - 0.394"
Cable O.D. (Approx.)	25 Conductor, 24 AWG - 0.335"
Cable O.D. (Approx.)	15 Conductor, 24 AWG - 0.256"
Voltage Rating	300 V
Amperage	2.0 Amps/Conductor
Degree of Protection	25 Conductor, 22 AWG - 2.0 A/Conductor
Operating Temperature	Max 80°C
Jack Screws	4-40 Thread

CONNECTOR (CABLE)	CONDUCTOR
Pin 1	Black
Pin 2	White
Pin 3	Red
Pin 4	Green
Pin 5	Orange
Pin 6	Blue
Pin 7	White/Black
Pin 8	Red/Black
Pin 9	Green/Black
Pin 10	Orange/Black
Pin 11	Blue/Black
Pin 12	Black/White
Pin 13	Red/White
Pin 14	Green/White
Pin 15	Blue/White
Pin 16	Black/Red
Pin 17	White/Red
Pin 18	Orange/Red
Pin 19	Blue/Red
Pin 20	Red/Green
Pin 21	Orange/Green
Pin 22	Black/White/Red or Brown/White
Pin 23	White/Black/Red or Yellow/Black
Pin 24	Red/Black/White or Violet/White
Pin 25	Green/Black/White or Gray/Black
Pin 26	Orange/Black/White or Yellow
Pin 27	Blue/Black/White or Violet
Pin 28	Black/Red/Green or Gray
Pin 29	White/Red/Green or Pink
Pin 30	Red/Black/Green or Light Green
Pin 31	Green/Black/Orange or Orange/ White
Pin 32	Orange/Black/Green or Pink/Black
Pin 33	Blue/White/Orange or Pink/Green
Pin 34	Black/White/Orange or Pink/Red
Pin 35	White/Red/Orange or Pink/Violet
Pin 36	Orange/ White/Blue or Light Blue
Pin 37	White/Red/Blue or Light Brown
Not Used	Black/White/Green
Not Used	White/Black/Green
Not Used	Red/White/Green



Input Distribution Boxes

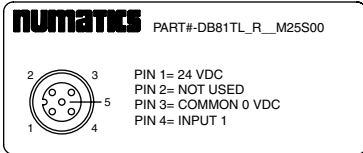
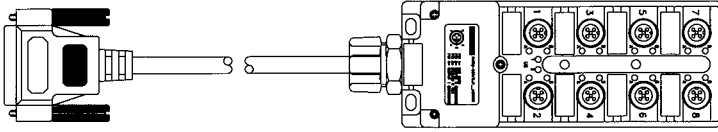

25 Pin SUB-D CONNECTOR. SINGLE POINT - 8 INPUTS

8 Port Distribution Box - 5 Pin 3 Wire/LED - NPN (Sinking)

2 Meters - DB81TLNR02M25S00

5 Meters - DB81TLNR05M25S00

10 Meters - DB81TLNR10M25S00

8 Port Distribution Box - 5 Pin 3 Wire/LED - PNP (Sourcing)

2 Meters - DB81TLPR02M25S00

5 Meters - DB81TLPR05M25S00

10 Meters - DB81TLPR10M25S00

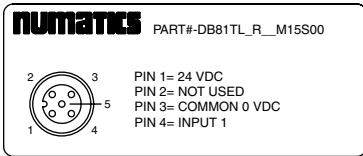
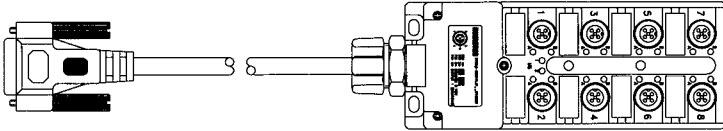

15 Pin SUB-D CONNECTOR. SINGLE POINT - 8 INPUTS

8 Port Distribution Box - 5 Pin 3 Wire/LED - NPN (Sinking)

2 Meters - DB81TLNR02M15S00

5 Meters - DB81TLNR05M15S00

10 Meters - DB81TLNR10M15S00

8 Port Distribution Box - 5 Pin 3 Wire/LED - PNP (Sourcing)

2 Meters - DB81TLPR02M15S00

5 Meters - DB81TLPR05M15S00

10 Meters - DB81TLPR10M15S00

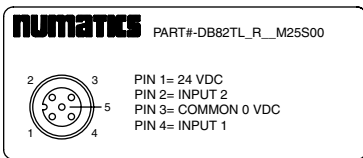
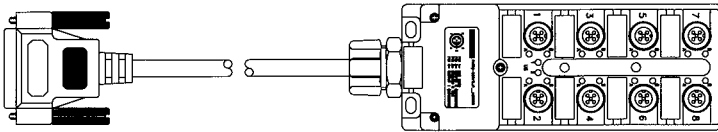

25 Pin SUB-D CONNECTOR. DOUBLE POINT - 16 INPUTS

8 Port Distribution Box - 5 Pin 4 Wire/LED - NPN (Sinking)

2 Meters - DB82TLNR02M25S00

5 Meters - DB82TLNR05M25S00

10 Meters - DB82TLNR10M25S00

8 Port Distribution Box - 5 Pin 4 Wire/LED - PNP (Sourcing)

2 Meters - DB82TLPR02M25S00

5 Meters - DB82TLPR05M25S00

10 Meters - DB82TLPR10M25S00

Go to www.numatics.com/wiringdiagrams for wiring information

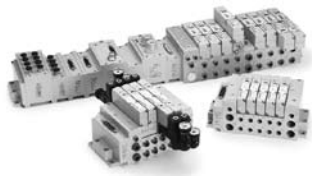

Output Distribution Boxes

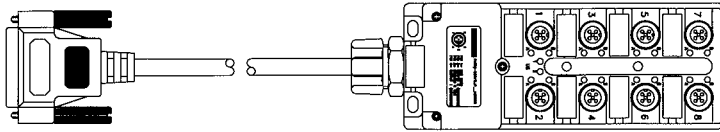

25 Pin SUB-D CONNECTOR SINGLE POINT - 8 OUTPUTS

8 Port Distribution Box - 5 Pin 3 Wire/LED - PNP (Sourcing)

2 Meters - DB81TLJP02M25S00

5 Meters - DB81TLJP05M25S00

10 Meters - DB81TLJP10M25S00

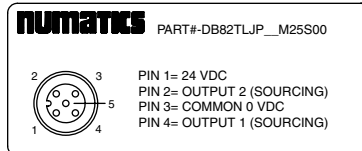
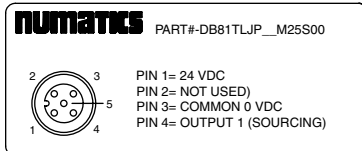

25 Pin SUB-D CONNECTOR DOUBLE POINT - 16 OUTPUTS

8 Port Distribution Box - 5 Pin 4 Wire/LED - PNP (Sourcing)

2 Meters - DB82TLJP02M25S00

5 Meters - DB82TLJP05M25S00

10 Meters - DB82TLJP10M25S00

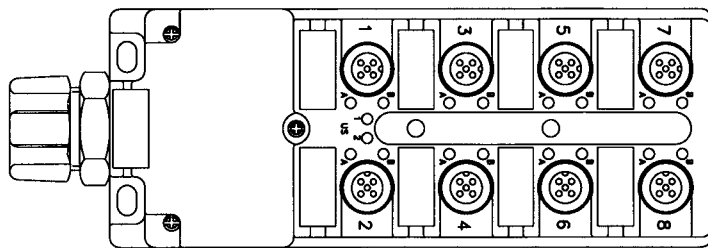

D-BOXES WITHOUT CABLE - UNIVERSAL

8 Port Block - 5 Pin w/ LED's - NPN

DB82TLN000000000

8 Port Block - 5 Pin w/ LED's - PNP

DB82TLP000000000

8 Port Block - 5 Pin without LED's - Universal

DB82T0U000000000

Go to www.numatics.com/wiringdiagrams for wiring information

TECHNICAL DATA

Molded Body/Housing	Pocan PBT
Threaded Sleeve	CuZn, Nickel Plated
Voltage Rating	10 - 30 VDC
Amperage	2 A per Signal
Protection	IP 68, NEMA 6P
Operating Temperature	-20°C to 90°C
Wire Range	26 - 24 AWG

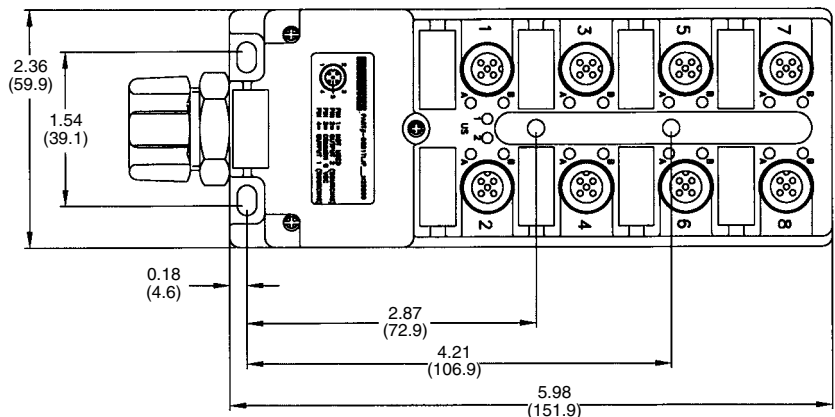

NUMATICS

*World Class Supplier
of Pneumatic Components*

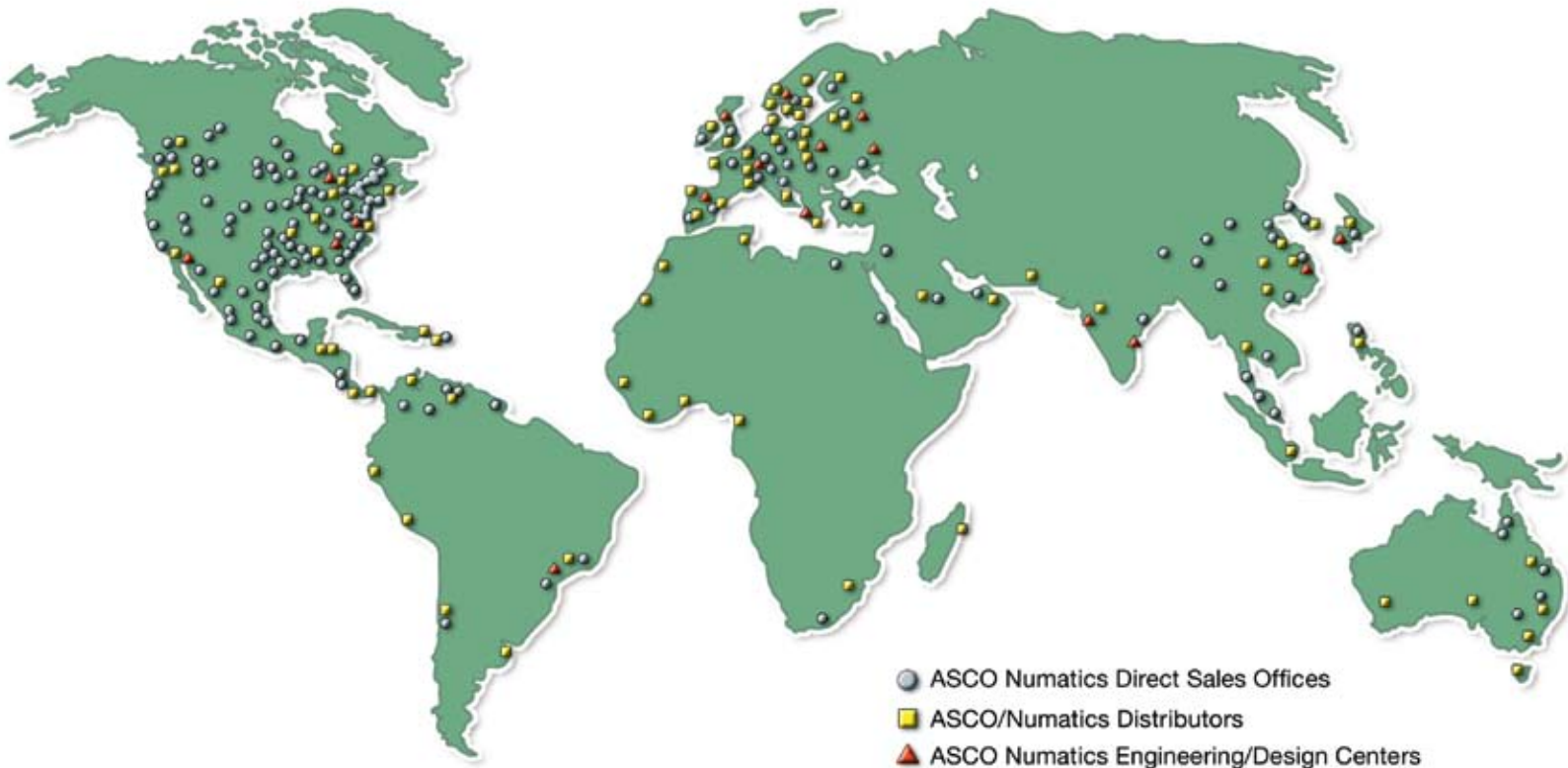

WORLD HEADQUARTERS

USA

Numatics, Incorporated

46280 Dylan Drive
Novi, Michigan 48377

P: 1-888-Numatics
1-888-686-2842

Canada

Numatics, Ltd

P: 519-452-1777

Mexico

Numatics de Mexico S.A. de C.V.

P: 52-222-284-6176

For a comprehensive listing of all Numatics production and distribution facilities worldwide, visit:

www.numatics.com